

SERIES 44 - 49

High Performance Butterfly Valve

Wafer, Lug, Double Flanged



W.T. Maye, Inc. (WTMI)
1-877-705-9864
info@wtmi-usa.com
www.wtmi-usa.com



STANDARD FEATURES

Quality & Performance

DelVal Flow Controls provides a wide range of quality products with the reliability you can count on. All Series 44 - 49 high performance butterfly valves are manufactured in ISO 9001 certified facilities with a robust quality management system and according to ASME B16.34 and API 609 standards.

Design Construction and Features

1. Top Flange

The top flange is drilled as per EN ISO 5211 to accommodate direct mounting of a wide range of actuators and manual operators.

2. Body

One-piece wafer, lug, or double flanged style body offers bidirectional sealing as standard, available in ASME CL150 and CL300 pressure classes.

3. Wedge Keys

Keys are offset from the center of the stem which places them in compression rather than shear, eliminating potential for failure. The keys are wedge type and precision fit to provide positive mechanical engagement of disc to stem.

4. Disc Stop

The disc stop is designed to prevent disc from rotating in the wrong direction and avoiding seat damage.

5. Seat Retainer

Retains seat in the body and is supplied in the equivalent material as the body.

6. Stem Seal

Gland flange assembly is "live loaded" with Belleville springs. This ensures continuous compression of packing and sealing contact at the stem and body. Rocker shaped gland bridge compensates for uneven adjustment of gland bolts.

7. Blow-out Proof Stem

Valves are equipped with a stem retainer at the top of the stem to prevent movement of the top portion of the stem past the compressing ring in case the shaft should break within the valve.

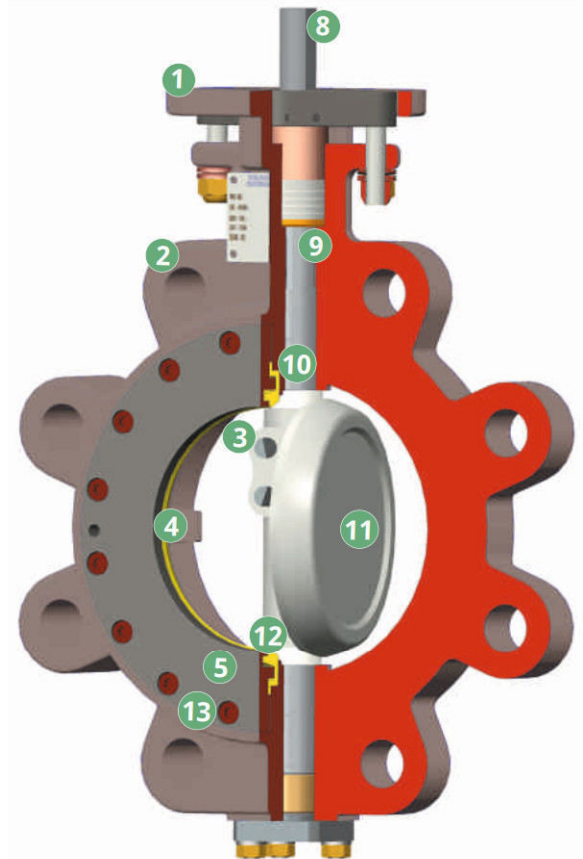
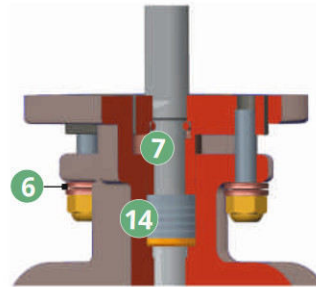

8. Stem

A sturdy, one-piece stem provides increased torsional strength for higher torque applications.

9. Extended Neck

Extended neck allows for 2" of pipeline insulation and easy access to stem packing adjustment and actuator mounting.

10. Bearings

The drive and non-drive end stem "Bear-X" bearings are made out of an engineered, high compressive strength composite polymer material having excellent thermal, chemical and wear resistance.

11. Disc

The disc has been engineered to maximize flow and minimize resistance to provide a high flow coefficient (Cv).

12. Seat

Unique seat design utilizes a self-energizing, flexible lip seal concept which provides bi-directional sealing without relying on secondary components, avoiding thermal and chemical incompatibility of dissimilar materials.

13. Bi-Directional Dead End Service

All lug and double flange valves are suitable for dead-end service to full ASME pressure rating, bi-directionally.

14. Adjustable Stem Packing

The stem packing system features an easy access to the adjusting hex head nuts without removal of the actuator.

Design and Specifications

Double Offset Design

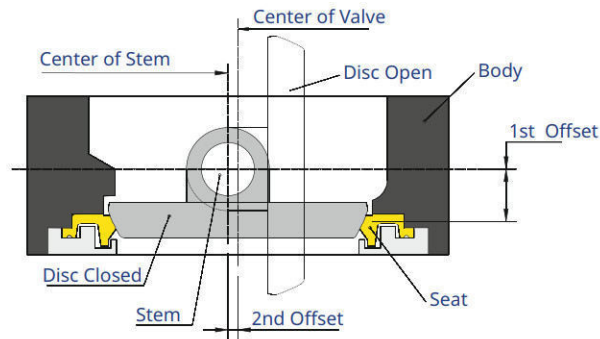

The double offset design produces a cam-like action in disc movement. This action reduces seat wear and eliminates seat deformation, thereby extending service life and reducing operating torques when compared to centric butterfly valves.

Seat Designs

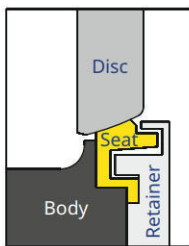

Soft Seat

Soft Seat: Self-energizing flexible lip seat design retains its original shape and maintains a seal against the disc regardless of the flow direction.

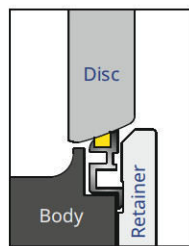

Fire Safe Seat

Fire Safe Seat: During and after fire, when the resilient material has been partially or completely destroyed, the backup metal seat ring provides two points of contact seals in either direction of media flow.

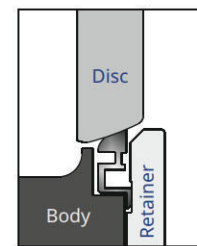

Metal Seat

Metal Seat: Flexible metal seat offers a very high sealing capability with low leakage rates. The mechanical properties and the shape of the metal seat allow it to flex and maintain constant positive sealing against the disc.

Special Applications

Vacuum

Standard soft seat and fire safe seat valves are rated for tight shut-off of vacuum to 1 mbar.

Oxygen

Valves for critical gaseous oxygen service are specially prepared, cleaned, inspected, assembled and tested to ensure removal of all burrs, sharp edges, dirt, hydrocarbon oil or grease and other contaminants.

NACE Service

Valves conforming to NACE MR0175 and MR0103 are available. These valves are well suited for oil and gas industry applications requiring resistant materials to sulfide stress cracking.

Steam

Valves are suitable for saturated steam up to 200psig for CL150 and up to 450psig for CL300 with ULTRA seat (with seat temperature limits per pressure-temperature diagram, and appropriate packing and seals to be chosen based on design temperature conditions).

Standards and Specifications

DelVal Double Offset High Performance Butterfly Valves are designed and manufactured to meet the requirements of the following industry standards:

Reference Design Standards: API 609, BS EN 593, MSS SP-68

Face to Face: API 609, ISO 5752, BS EN 558, MSS SP-68

Testing: API 598, ISO 5208, BS EN 12266, MSS SP-68

Pressure Temperature: ASME B16.34

Flange Accommodation: ASME B16.5, ASME B16.47, other international standards

NACE (optional): ANSI / NACE MR0175 / ISO 15156, ANSI / NACE MR0103 / ISO 17945

Fire Safe Certified (optional): API 607

Fugitive Emission (optional): ISO 15848

Pressure Equipment Compliance: PED 2014 / 68 / EU

Body Style: Wafer, Lug, Double Flanged

Pressure Rating: CL150 to CL300

Temp. Range*: -58°F to 500°F (Soft Seat / Fire Safe Seat)
-58°F to 800°F (Metal Seat)

Size Range:** 2" to 60"

*Pressure-temperature rating shall be lesser of the shell rating or the seat rating.

**Consult DelVal for sizes not available in the catalog.

DIMENSIONS AND WEIGHTS

WAFER & LUG

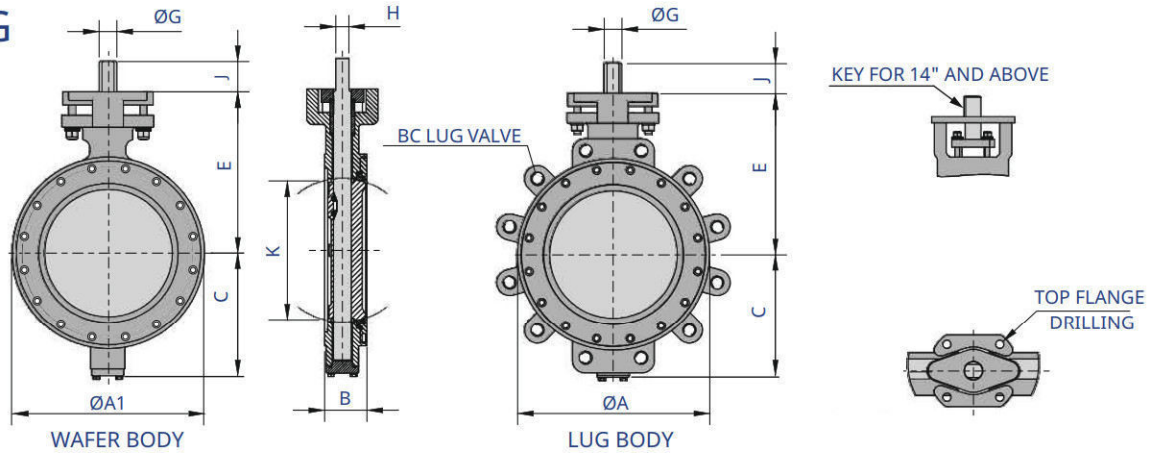

Dimensions (Inch)

ASME CLASS 150 WAFER/LUG (SERIES 44/45)

Valve Size		Top Flanged Drilling										Lug Drilling D			App. Weight (lbs)				
Inch	DN	ØA	ØA1	*B	C	E	BC	No. of Holes	Hole Dia.	ØG	H	J	Key Size	K	BC	No. of Holes	Tapping/UNC/UNZB	Wafer	Lug
2	50	3.82	3.82	1.69	2.68	4.92	2.76	4	0.39	0.55	0.39	1.26	-	1.57	4.75	4	5/8-11	7.3	9.5
2 1/2	65	4.13	4.13	1.88	2.95	5.75	2.76	4	0.39	0.63	0.43	1.26	-	2.19	5.50	4	5/8-11	8.8	11.0
3	80	5.47	5.47	1.88	4.25	5.91	2.76	4	0.39	0.63	0.43	1.26	-	2.69	6.00	4	5/8-11	13.9	15.4
4	100	6.69	6.69	2.13	4.84	6.77	2.76	4	0.39	0.63	0.43	1.26	-	3.53	7.50	8	5/8-11	18.3	26.5
5	125	7.32	7.32	2.24	5.47	7.40	2.76/4.02	4	0.39/0.43	0.75	0.51	1.26	-	4.36	8.50	8	3/4-10	19.8	29.5
6	150	8.50	8.50	2.24	5.83	8.07	2.76/4.02	4	0.39/0.47	0.75	0.51	1.26	-	5.46	9.50	8	3/4-10	30.9	35.3
8	200	10.59	10.59	2.52	6.81	9.45	4.92	4	0.55	0.87	0.63	1.26	-	7.21	11.75	8	3/4-10	48.5	63.9
10	250	12.76	12.76	2.80	8.54	10.71	4.92	4	0.55	1.18	0.87	2.01	-	9.16	14.25	12	7/8-9	70.5	94.8
12	300	15.00	14.88	3.19	9.80	12.20	4.92	4	0.55	1.38	0.94	2.01	-	10.93	17.00	12	7/8-9	106.9	147.7
14	350	16.26	16.26	3.62	11.18	15.94	4.92/5.51	4	0.55/0.71	1.57	-	2.01	0.47 x 0.31	12.12	18.75	12	1-8	185.2	238.1
16	400	18.50	18.50	4.02	12.40	17.95	5.51/6.50	4	0.71/0.87	1.97	-	2.52	0.47 x 0.31	13.94	21.26	16	1-8	260.1	328.5
18	450	21.02	21.02	4.49	13.35	19.33	5.51/6.50	4	0.71/0.87	2.17	-	2.52	0.63 x 0.39	15.94	22.75	16	1 1/8-8	339.5	390.2
20	500	22.99	22.99	5.00	14.76	21.10	6.50	4	0.87	2.36	-	4.02	0.71 x 0.43	17.57	25.00	20	1 1/8-8	449.7	566.6
24	600	27.36	27.36	6.06	17.24	24.96	6.50/10	8	0.87/0.71	2.76	-	4.02	0.79 x 0.47	20.97	29.50	20	1 1/4-8	776.0	892.9
26	650	29.49	29.49	6.50	18.70	26.93	10.00	8	0.71	3	-	4.02	0.75 x 0.75	23.82	31.75	24	1 1/4-8	1135.0	1365.0
28	700	31.50	30.00	6.50	19.69	28.74	10/11.73	8	0.71/0.87	3	-	4.02	0.75 x 0.75	24.61	34.00	28	1 1/4-8	1135.4	1366.9
30	750	33.74	33.74	7.48	21.26	28.35	10/11.73	8	0.71/0.87	3.50	-	4.02	0.88 x 0.63	25.59	36.00	28	1 1/4-8	1140.0	1580.7
32	800	35.98	34.02	7.48	22.05	30.75	11.73	8	0.87	3.50	-	4.02	0.88 x 0.63	27.44	38.50	28	1 1/2-8	1450.6	1873.9
36	900	40.24	37.99	7.99	25.59	33.86	11.73	8	0.87	4.00	-	5.27	1.00 x 0.75	31.00	42.75	32	1 1/2-8	1907.0	2641.1
40	1000	44.25	44.25	9.88	28.35	38.19	14.02	8	1.30	4.72	-	5.90	1.26 x 0.71	35.04	47.25	36	1 1/2-8	3483.0	4299.0
42	1050	47.00	47.00	10.00	32.40	43.70	14.02	8	1.30	4.72	-	5.90	1.26 x 0.71	38.00	49.50	36	1 1/2-8	4078.0	5070.0
44	1100	49.02	49.02	10.00	30.51	40.16	14.02	8	1.30	5.11	-	5.90	1.26 x 0.71	40.94	51.75	40	1 1/2-8	4409.0	5622.0
48	1200	53.50	53.50	10.88	31.89	42.52	14.02	8	1.30	5.11	-	5.90	1.26 x 0.71	44.02	56.00	44	1 1/2-8	4960.0	6173.0

ASME CLASS 300 WAFER/LUG (SERIES 47/48)

2	50	4.02	4.02	1.69	3.39	5.24	2.76	4	0.39	0.55	0.39	1.26	-	1.49	5.00	8	5/8-11	7.7	11.0
2 1/2	65	4.13	4.13	1.81	3.86	5.75	2.76	4	0.39	0.63	0.43	1.26	-	1.99	5.87	8	3/4-10	8.8	12.1
3	80	5.20	5.47	1.89	4.29	6.22	2.76	4	0.39	0.63	0.43	1.26	-	2.67	6.63	8	3/4-10	13.4	18.7
4	100	6.69	6.69	2.13	4.84	6.77	2.76	4	0.39	0.63	0.43	1.26	-	3.55	7.87	8	3/4-10	19.0	26.5
5	125	7.32	7.32	2.32	5.47	7.99	2.76/4.02	4	0.39/0.43	0.75	0.51	1.26	-	4.17	9.25	8	3/4-10	20.3	36.8
6	150	8.50	8.50	2.32	6.42	8.66	2.76/4.02	4	0.39/0.47	0.87	0.63	1.26	-	5.42	10.63	12	3/4-10	39.7	55.1
8	200	10.63	10.63	2.87	7.87	10.94	4.92	4	0.55	1.18	0.87	2.01	-	7.16	13.00	12	7/8-9	70.5	94.8
10	250	12.83	12.83	3.27	9.06	11.81	4.92	4	0.55	1.38	0.94	2.01	-	8.87	15.25	16	1-8	100.0	134.5
12	300	15.00	15.00	3.62	10.51	13.43	5.51/6.50	4	0.71/0.87	1.57	1.14	2.01	-	10.75	17.75	16	1 1/8-8	172.4	220.5
14	350	16.26	16.26	4.61	12.40	17.99	5.51/6.50	4	0.71/0.87	2.17	-	2.52	0.63 x 0.39	11.38	20.25	20	1 1/8-8	286.6	381.4
16	400	18.50	18.50	5.24	14.37	20.79	6.50	4	0.87	2.17	-	2.52	0.63 x 0.39	13.37	22.50	20	1 1/4-8	392.4	493.8
18	450	20.98	20.98	5.87	15.08	23.27	10.00	8	0.71	2.76	-	4.02	0.79 x 0.47	14.99	24.75	24	1 1/4-8	485.0	848.8
20	500	22.99	22.99	6.26	17.17	23.70	10/11.73	8	0.71/0.87	3.15	-	4.02	0.87 x 0.55	16.07	27.00	24	1 1/4-8	877.4	998.7
24	600	27.24	27.24	7.13	19.84	31.30	11.73	8	0.87	3.94	-	5.28	1.10 x 0.63	19.71	32.00	24	1 1/2-8	1157.4	1862.9

*Face to Face dimension 'B' conforms to API 609 Category B / BS EN 558 for sizes up to 24", CL150 and CL300. Please consult DelVal for other dimensions. DelVal reserves rights to change the contents without notice.

DIMENSIONS AND WEIGHTS

DOUBLE FLANGED

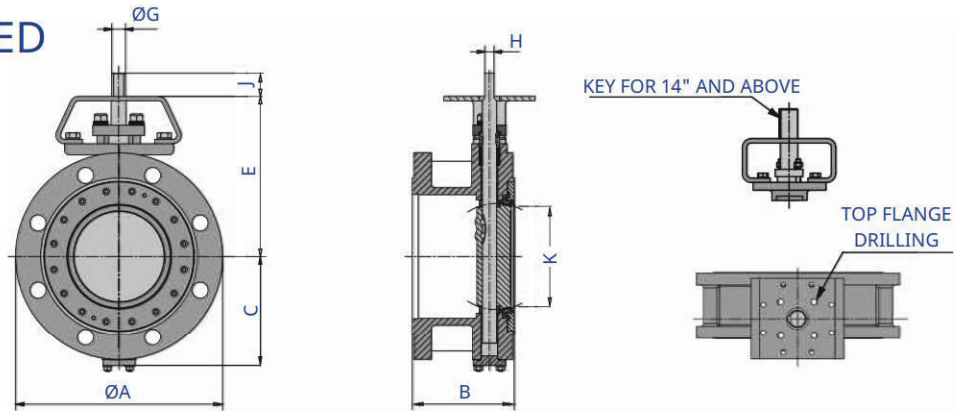

DOUBLE FLANGED BODY

Dimensions (Inch)

ASME CLASS 150 DOUBLE FLANGE (SERIES 46)

Valve Size		Top Flanged Drilling											App. Weight (lbs)	
Inch	DN	ØA	*B	C	E	BC	No. of Holes	Hole Dia.	ØG	H	J	Key Size		K
2	50	6.50	4.29	3.66	6.42	1.97/2.76	4	0.31/0.35	0.55	0.39	1.26	-	1.39	24.25
2 1/2	65	7.01	4.41	3.98	6.38	2.76	4	0.35	0.63	0.43	1.26	-	1.50	26.50
3	80	7.95	4.49	4.65	7.48	2.76/4.02	4	0.35/0.43	0.63	0.43	1.26	-	2.15	34.17
4	100	9.06	5.00	5.47	8.66	2.76/4.02	4	0.35/0.43	0.63	0.43	1.26	-	3.14	47.40
5	125	10.04	5.51	5.47	8.66	2.76/4.02	4	0.39/0.43	0.75	0.51	1.26	-	3.77	66.14
6	150	11.22	5.51	5.94	8.66	2.76/4.02	4	0.35/0.43	0.75	0.51	1.26	-	5.12	72.75
8	200	13.58	5.98	7.20	10.91	4.02/4.92	4	0.43/0.51	0.87	-	1.26	0.24 x 0.24	7.05	116.84
10	250	15.94	6.50	8.54	11.97	4.02/4.92	4	0.43/0.51	1.18	-	2.01	0.31 x 0.28	8.84	160.94
12	300	19.09	7.01	10.24	14.96	4.92	4	0.51	1.38	-	2.01	0.39 x 0.31	10.64	233.69
14	350	21.06	7.48	11.18	15.94	4.92/5.51	4	0.55/0.71	1.57	-	2.01	0.47 x 0.31	11.66	374.78
16	400	23.43	8.50	12.40	19.06	5.51/6.50	4	0.71/0.87	1.97	-	2.52	0.47 x 0.39	13.64	436.51
18	450	25.00	8.74	13.35	19.33	5.51/6.50	4	0.71/0.87	2.17	-	2.52	0.63 x 0.39	15.63	617.29
20	500	27.56	9.02	15.35	22.72	6.50/10.00	4/8	0.87/0.71	2.36	-	4.02	0.71 x 0.43	17.31	769.41
24	600	32.09	10.51	18.03	25.59	10.00	8	0.71	2.76	-	4.02	0.79 x 0.47	20.59	1062.62
26	650	34.25	11.50	18.70	26.93	10.00	8	0.71	3.00	-	4.02	0.75 x 0.75	23.82	1165.00
28	700	36.42	11.50	19.69	28.74	10.00/11.73	8	0.71/0.87	3.00	-	4.02	0.75 x 0.75	24.13	1370.00
30	750	38.78	12.52	21.26	29.33	10.00/11.73	8	0.71/0.87	3.50	-	4.02	0.88 x 0.63	25.40	1907.00
32	800	41.73	12.52	22.05	30.75	11.73	8	0.87	3.50	-	4.02	0.88 x 0.63	27.12	2000.00
36	900	46.06	12.99	25.59	33.86	11.73	8	0.87	4.00	-	5.27	1.00 x 0.75	30.52	2561.00
40	1000	50.79	16.14	28.35	39.37	14.02	8	1.30	4.72	-	5.90	1.26 x 0.71	34.62	5357.00
42	1050	52.95	16.14	32.40	43.70	14.02	8	1.30	4.72	-	5.90	1.26 x 0.71	35.04	6338.00
44	1100	55.31	18.50	30.51	41.34	14.02	8	1.30	5.11	-	5.90	1.26 x 0.71	40.94	7010.00
48	1200	59.45	18.50	31.89	49.21	14.02	8	1.30	5.11	-	5.90	1.26 x 0.71	43.59	7716.00

ASME CLASS 300 DOUBLE FLANGE (SERIES 49)

3	80	8.27	4.49	4.29	6.89	2.76	4	0.39	0.63	0.43	1.26	-	2.22	44.09
4	100	10.04	5.00	4.84	7.48	2.76	4	0.39	0.63	0.43	1.26	-	3.14	55.12
5	125	11.02	5.51	5.47	7.87	2.76/4.02	4	0.39/0.43	0.75	0.51	1.26	-	3.34	123.46
6	150	12.60	5.51	6.81	9.65	2.76/4.02	4	0.39/0.47	0.87	-	1.26	0.24 x 0.24	5.11	127.87
8	200	14.96	5.98	8.15	12.01	4.92	4	0.55	1.18	-	2.01	0.31 x 0.28	6.96	196.21
10	250	17.52	6.50	9.45	13.82	4.92	4	0.55	1.38	-	2.01	0.39 x 0.31	8.71	284.39
12	300	20.47	7.01	10.91	15.75	5.51/6.50	4	0.71/0.87	1.57	-	2.01	0.47 x 0.31	10.54	354.94
14	350	23.03	7.48	12.52	17.99	6.50	4	0.87	2.17	-	2.52	0.63 x 0.39	10.97	416.67
16	400	25.59	8.50	14.37	20.79	6.50	4	0.87	2.17	-	2.52	0.63 x 0.39	12.67	734.13
18	450	27.95	8.74	15.75	23.27	10.00	8	0.71	2.76	-	4.02	0.79 x 0.47	14.07	727.52
20	500	30.51	9.02	17.17	23.70	10.00	8	0.71	3.15	-	4.02	0.87 x 0.55	15.29	1179.46
24	600	36.02	10.51	19.84	31.30	11.73	8	0.87	3.94	-	5.28	1.10 x 0.63	18.74	1902.00

*Face to Face dimension 'B' conforms to API 609 Category B up to 24", CL150 and CL300. Please consult DeVal for other dimensions.

DeVal reserves rights to change the contents without notice.

TORQUE DATA Lbf-Inch

ASME CLASS 150

Soft Seat

Valve Size		Differential Pressure (ΔP)				
		50 Psi	100 Psi	150 Psi	230 Psi	290 Psi
Inch	DN	Preferred Flow Direction				
2	50	212	230	239	248	257
2 1/2	65	239	248	257	274	283
3	80	283	292	301	327	354
4	100	381	407	434	469	602
5	125	522	575	620	690	735
6	150	779	841	920	1027	1097
8	200	1310	1434	1549	1761	1894
10	250	1708	1938	2160	2505	2788
12	300	2080	2522	2974	3655	4116
14	350	3443	4266	5125	6505	7399
16	400	4390	5470	6585	8284	9523
18	450	5718	7151	8550	10833	12471
20	500	7629	9621	11471	14719	16790
24	600	11550	14586	17772	22640	26181
26	650	14135	17259	19560	23100	28057
28	700	15533	19029	22038	25048	29739
30	750	21198	25773	30349	37669	42705
32	800	27428	33297	40085	48290	55981
36	900	34208	42147	50086	62787	71523
40	1000	54007	67275	80542	101775	116405
42	1050	60920	73213	86012	108687	124291
44	1100	68372	79303	91340	115414	131965
48	1200	88065	110192	130726	166447	189583

Note:

1.Flow from retainer side is the preferred flow direction.

Flow from stem side is non-preferred flow direction. Arrow on valve body indicates the preferred flow direction.

2.BTO-Break to Open; RTO-Run to Open; ETO-End to Open; BTC-Break to Close; RTC-Run to Close; ETC-End to Close.

3.Above mention tabulated torque values are BTO & ETC for preferred flow direction.

4.RTO, ETO, BTC & RTC = 40% of the above tabulated values for preferred direction.

5.For non-preferred flow direction torque values of soft seat,

2" to 8" - multiply preferred values by 1.12,

10" to 12" - multiply preferred values by 1.20,

14" to 24" - multiply preferred values by 1.24,

26" to 48" - multiply preferred values by 1.30

6.For non-preferred flow direction torque values of fire safe seat & metal seat , multiply preferred values by 1.25

7.For actuator sizing, the minimum valve differential pressure shall be 50 psi. For differential pressures above 50 psi the intermediated values to be interpolated. For gear operator sizing, the full rated torque to be considered.

8.The published torque values are without factor of safety.

The following factor of safety shall be considered for operator sizing:

Clean service (liquid, steam, clean gas and non-abrasive) = 1.3

High solids slurry = 1.5

Dry gas = 1.7

DelVal reserves rights to change the contents without notice.

Fire Safe Seat

Valve Size		Differential Pressure (ΔP)				
		50 Psi	100 Psi	150 Psi	230 Psi	290 Psi
Inch	DN	Preferred Flow Direction				
2	50	460	478	496	522	540
2 1/2	65	478	504	513	540	558
3	80	611	628	646	682	708
4	100	752	797	832	894	947
5	125	850	920	1000	1124	1213
6	150	1425	1549	1682	1885	2000
8	200	2337	2593	2788	3142	3425
10	250	3523	3921	4372	5063	5558
12	300	5248	6036	6797	7930	8824
14	350	6231	7143	8010	9559	10532
16	400	7187	8355	9683	11621	13055
18	450	9152	11409	13905	17524	20224
20	500	12949	16445	19817	25632	29349
24	600	20392	24109	28075	34394	38253
26	650	23181	28305	32079	37885	46013
28	700	25474	31208	36143	41078	48771
30	750	34764	42268	49773	61777	70036
32	800	44983	54606	65739	79195	91809
36	900	56101	69122	82142	102971	117298
40	1000	88572	110330	132089	166911	190904
42	1050	99908	120070	141059	178247	203837
44	1100	112130	130056	149797	189279	216422
48	1200	144427	180715	214390	272973	310916

Metal Seat

Valve Size		Differential Pressure (ΔP)				
		50 Psi	100 Psi	150 Psi	230 Psi	290 Psi
Inch	DN	Preferred Flow Direction				
2	50	513	531	558	584	620
2.5	65	602	620	646	673	699
3	80	743	788	805	832	876
4	100	947	1000	1036	1106	1186
5	125	1053	1142	1266	1407	1513
6	150	1779	1938	2089	2345	2478
8	200	2947	3266	3487	3947	4266
10	250	4337	4903	5523	6257	7036
12	300	6612	7488	8532	9895	11099
14	350	7789	9037	10019	11922	13143
16	400	8984	10479	12081	14639	16277
18	450	11524	14489	17206	22180	25039
20	500	16055	20392	24685	32199	36722
24	600	25490	30376	35022	43156	47688

TORQUE DATA Lbf-Inch

ASME CLASS 300

Soft Seat

Valve Size		Differential Pressure (ΔP)				
		150 Psi	290 Psi	360 Psi	580 Psi	750 Psi
Inch	DN	Preferred Flow Direction				
2	50	239	257	283	354	372
2.5	65	257	283	301	372	416
3	80	301	354	389	478	531
4	100	434	602	655	841	956
5	125	779	982	1089	1425	1646
6	150	1062	1363	1549	2071	2434
8	200	2018	2655	3018	4062	4824
10	250	2992	4080	4691	6470	7753
12	300	4186	5656	6426	8868	10524
14	350	6408	9364	11134	15993	19419
16	400	7780	11240	13205	19303	23410
18	450	10054	14621	17126	24658	29836
20	500	13285	19392	23056	33288	40616
24	600	18117	26366	30845	45148	54503

Note:

- Flow from retainer side is the preferred flow direction. Flow from stem side is non-preferred flow direction. Arrow on valve body indicates the preferred flow direction.
- BTO-Break to Open; RTO-Run to Open; ETO-End to Open; BTC-Break to Close; RTC-Run to Close; ETC-End to Close.
- Above mention tabulated torque values are BTO & ETC for preferred flow direction.
- RTO, ETO, BTC & RTC = 40% of the above tabulated values for preferred direction.
- For non-preferred flow direction torque values of soft seat, fire safe seat & metal seat, multiply preferred values by 1.25
- For actuator sizing, the minimum valve differential pressure shall be 150 psi. For differential pressures above 150 psi the intermediated values to be interpolated. For gear operator sizing, the full rated torque to be considered.
- The published torque values are without factor of safety. The following factor of safety shall be considered for operator sizing:
Clean service (liquid, steam, clean gas and non-abrasive) = 1.3
High solids slurry = 1.5
Dry gas = 1.7

DelVal reserves rights to change the contents without notice.

Fire Safe Seat

Valve Size		Differential Pressure (ΔP)				
		150 Psi	290 Psi	360 Psi	580 Psi	750 Psi
Inch	DN	Preferred Flow Direction				
2	50	496	540	558	593	620
2.5	65	513	558	584	620	655
3	80	646	708	726	770	814
4	100	832	947	1071	1275	1434
5	125	1097	1283	1390	1717	1921
6	150	1814	2186	2399	3009	3443
8	200	2983	3647	4009	5098	5833
10	250	4478	5399	5921	7417	8532
12	300	7302	9541	10639	14303	16816
14	350	8196	10683	12055	16170	19003
16	400	9939	13409	15312	21295	25402
18	450	15285	22587	26738	38811	47431
20	500	21286	32031	37589	55618	67089
24	600	34199	50494	59318	85923	104129

Metal Seat

Valve Size		Differential Pressure (ΔP)				
		150 Psi	290 Psi	360 Psi	580 Psi	750 Psi
Inch	DN	Preferred Flow Direction				
2	50	558	620	664	699	735
2.5	65	646	699	735	788	805
3	80	805	876	903	956	1018
4	100	1036	1186	1328	1584	1788
5	125	1381	1593	1735	2133	2381
6	150	2257	2735	3009	3770	4319
8	200	3735	4523	5071	6381	7240
10	250	5549	6727	7328	9196	10621
12	300	9205	11807	13373	17808	21189
14	350	10143	13347	15073	20383	23773
16	400	12320	16728	19135	26632	31756
18	450	19109	28473	33146	48104	58840
20	500	26835	39926	47360	69859	83693
24	600	42590	63628	74205	107289	130212

STANDARD MATERIALS OF CONSTRUCTION

WAFER & LUG (2" to 12")

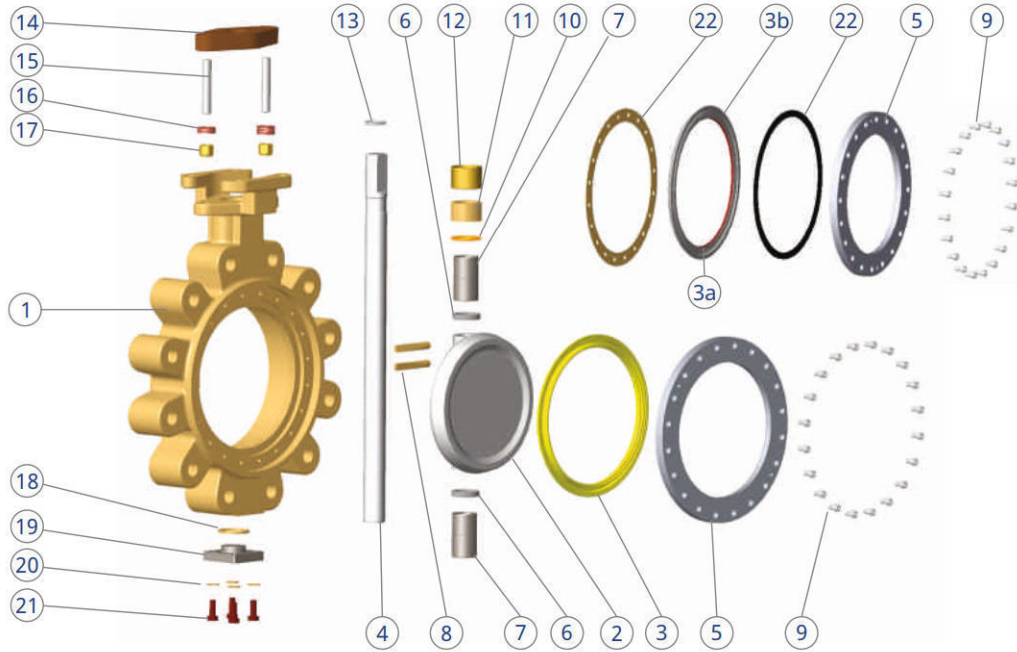

Part List

Item	Description	Standard Materials*	
		Carbon Steel	Stainless Steel
1	Body	ASTM A 216 WCB/WCC, ASTM A 352 LCC	ASTM A 351 CF8M/CF3M
2	Disc	ASTM A 351 CF8M/CF3M	ASTM A 351 CF8M/CF3M
3**	Seat (Soft)	PTFE#/ULTRA/RPTFE/UHMWPE	PTFE#/ULTRA/RPTFE/UHMWPE
3a**	Seat (Fire-Safe)	ASTM A 240 SS316 + ULTRA	ASTM A 240 SS316 + ULTRA
3b**	Seat (Metal)	ASTM A 240 SS316	ASTM A 240 SS316
4	Stem (Soft Seat)	ASTM A 322 4130 + ENP ASTM A 479 SS410 -cond. 3 ASTM A 564 Type 630 (17-4PH)	ASTM A 564 Type 630 (17-4PH) ASTM A 479 XM19 ASTM A 479 SS316 Strain Hardened Level 2
	Stem (Fire-Safe Seat)	ASTM A 479 SS410 -cond. 3 ASTM A 564 Type 630 (17-4PH)	ASTM A 564 Type 630 (17-4PH) ASTM A 479 XM19
	Stem (Metal Seat)	ASTM A 564 Type 630 (17-4PH)	ASTM A 564 Type 630 (17-4PH) ASTM A 479 XM19
5	Seat Retaining Ring	ASTM A 516 Gr. 70 Steel	ATM A 240 SS316/SS316L ASTM A 240 SS304
6	Disc Spacer	ASTM A 479 SS316/SS316L	ASTM A 479 SS316/SS316L
7**	Bearing (Soft Seat)	Bear-X	Bear-X
	Bearing (Fire-Safe Seat and Metal seat)	Fireproof DFP-D1	Fireproof DFP-D1
8**	Wedge Key	ASTM A 564 Type 630 (17-4PH)	ASTM A 564 Type 630 (17-4PH) ASTM A 479 XM19 ASTM A 479 SS316
9	Retainer Screw	ISO 3506 A4-70 ASTM A 1082 TYPE 630 (17-4PH) ASTM A 193 Gr. B8M	ISO 3506 A4-70 ASTM A 1082 TYPE 630 (17-4PH) ASTM A 193 Gr. B8M
10	Packing Spacer	ASTM A 479 SS316/SS316L	ASTM A 479 SS316/SS316L

Item	Description	Standard Materials*	
		Carbon Steel	Stainless Steel
11**	Gland Packing	PTFE (CHEVRON V- RING)/Graphite	PTFE (CHEVRON V- RING)/Graphite
12	Gland	ASTM A 479 SS316/ SS316L	ASTM A 479 SS316/ SS316L
13**	Stem Retainer	ASTM A 313 SS302	ASTM A 313 SS302
14	Gland Flange	ASTM A 516 Gr. 70 ASTM A105 ASTM A216 WCB Steel	ASTM A 240 SS316 ASTM A 351 CF8M ASTM A182 F316
15	Stud	ASTM A 193 Gr. B7 ASTM A 193 Gr. B7M ASTM A 193 Gr. B8M	ASTM A 193 Gr. B8M ASTM A 1082 TYPE 630 (17-4PH)
16**	Belleville Spring	ASTM A 666 SS 304	ASTM A 666 SS 316
17	Hex Nut	ASTM A 194 Gr. 8M ASTM A 194 Gr. 2H ASTM A 194 Gr. 2HM	ASTM A 194 Gr. 8M ASTM A 1082 TYPE 630 (17-4PH)
18**	Cover Gasket	PTFE/Graphite	PTFE/Graphite
19	Bottom Cover	ASTM A 516 Gr. 70 ASTM A 240 Ss304 Steel	ASTM A 240 SS316/ SS316L
20	Spring Washer	ASTM A 580 SS304	ASTM A 580 SS304
21	Hex Hd Screw	ISO 3506 A4-70 ASTM A 193 Gr. B7 ASTM A 193 Gr. B7M ASTM A 193 Gr. B8M	ISO 3506 A4-70 ASTM A 1082 TYPE 630 (17-4PH) ASTM A 193 Gr. B8M
22**	Seat Gasket (Fire-Safe Seat and Metal Seat)	Graphite	Graphite

*Other materials are available on request.

**Recommended spares.

Gland Packing/Cover Gasket MOC is dependent on application service.

#CL 150 only.

Item 18,19, 20 & 21 are not applicable for 2"/DN50 CL150

STANDARD MATERIALS OF CONSTRUCTION

WAFER & LUG (14" to 48")

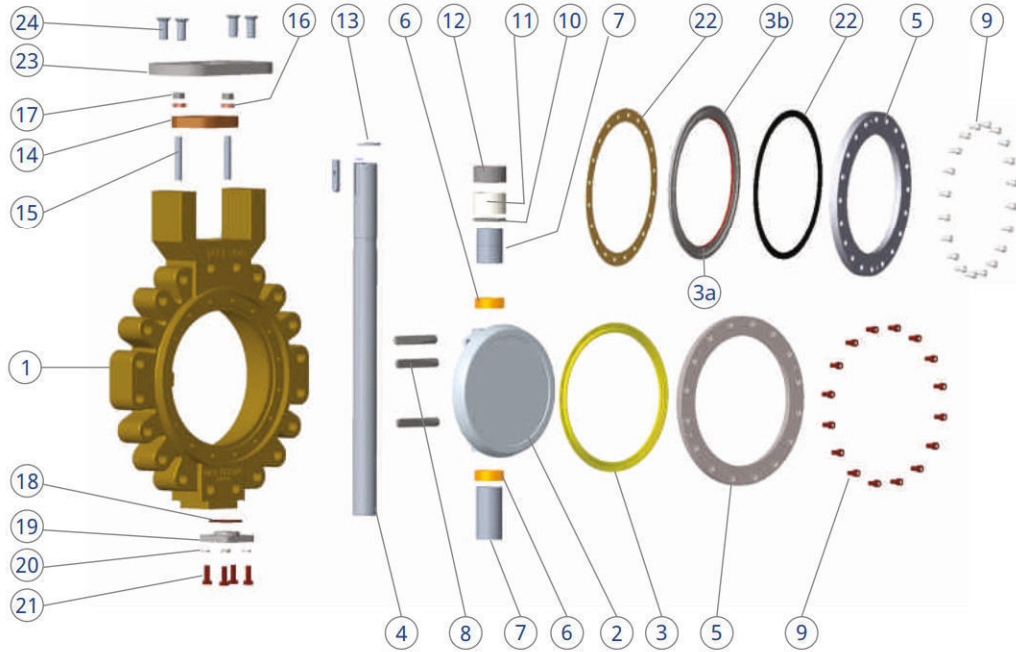

Part List

Item	Description	Standard Materials*	
		Carbon Steel	Stainless Steel
1	Body	ASTM A 216 WCB/WCC, ASTM A 352 LCC	ASTM A 351 CF8M/CF3M
2	Disc	ASTM A 351 CF8M/CF3M	ASTM A 351 CF8M/CF3M
3**	Seat (Soft)	PTFE#/ULTRA/RPTFE/UHMWPE	PTFE#/ULTRA/RPTFE/UHMWPE
3a**	Seat (Fire-Safe)	ASTM A 240 SS316 + ULTRA	ASTM A 240 SS316 + ULTRA
3b**	Seat (Metal)	ASTM A 240 SS316	ASTM A 240 SS316
4	Stem (Soft Seat)	ASTM A 322 4130 + ENP ASTM A 479 SS410 -cond. 3 ASTM A 564 Type 630 (17-4PH)	ASTM A 564 Type 630 (17-4PH) ASTM A 479 XM19 ASTM A 479 SS316 Strain Hardened Level 2
	Stem (Fire-Safe Seat)	ASTM A 479 SS410 -cond. 3 ASTM A 564 Type 630 (17-4PH)	ASTM A 564 Type 630 (17-4PH) ASTM A 479 XM19
	Stem (Metal Seat)	ASTM A 564 Type 630 (17-4PH)	ASTM A 564 Type 630 (17-4PH) ASTM A 479 XM19
5	Seat Retaining Ring	ASTM A 516 Gr. 70 Steel	ATM A 240 SS316/SS316L ASTM A 240 SS304
6	Disc Spacer	ASTM A 479 SS316/SS316L	ASTM A 479 SS316/SS316L
7**	Bearing (Soft Seat)	Bear-X	Bear-X
	Bearing (Fire-Safe) Seat and Metal seat)	Fireproof DFP-D1	Fireproof DFP-D1
8**	Wedge Key	ASTM A 564 Type 630 (17-4PH)	ASTM A 564 Type 630 (17-4PH) ASTM A 479 XM19 ASTM A 479 SS316
9	Retainer Screw	ISO 3506 A4-70 ASTM A 1082 TYPE 630 (17-4PH) ASTM A 193 Gr. B8M	ISO 3506 A4-70 ASTM A 1082 TYPE 630 (17-4PH) ASTM A 193 Gr. B8M
10	Packing Spacer	ASTM A 479 SS316/SS316L	ASTM A 479 SS316/SS316L

Item	Description	Standard Materials*	
		Carbon Steel	Stainless Steel
11**	Gland Packing	PTFE (CHEVRON V- RING)/Graphite	PTFE (CHEVRON V- RING)/Graphite
12	Gland	ASTM A 479 SS316/ SS316L	ASTM A 479 SS316/ SS316L
13**	Stem Retainer	ASTM A 313 SS302	ASTM A 313 SS302
14	Gland Flange	ASTM A 516 Gr. 70 ASTM A105 ASTM A216 WCB Steel	ASTM A 240 SS316 ASTM A 351 CF8M ASTM A182 F316
15	Stud	ASTM A 193 Gr. B7 ASTM A 193 Gr. B7M ASTM A 193 Gr. B8M	ASTM A 193 Gr. B8M ASTM A 1082 TYPE 630 (17-4PH)
16**	Belleville Spring	ASTM A 666 SS 304	ASTM A 666 SS 316
17	Hex Nut	ASTM A 194 Gr. 8M ASTM A 194 Gr. 2H ASTM A 194 Gr. 2HM	ASTM A 194 Gr. 8M ASTM A 1082 TYPE 630 (17-4PH)
18**	Cover Gasket	PTFE/Graphite	PTFE/Graphite
19	Bottom Cover	ASTM A 516 Gr. 70 ASTM A 240 SS304 Steel	ASTM A 240 SS316/ SS316L
20	Spring Washer	ASTM A 580 SS304	ASTM A 580 SS304
21	Hex Hd Screw	ISO 3506 A4-70 ASTM A 193 Gr. B7 ASTM A 193 Gr. B7M ASTM A 193 Gr. B8M	ISO 3506 A4-70 ASTM A 1082 TYPE 630 (17-4PH) ASTM A 193 Gr. B8M
22**	Seat Gasket (Fire- Safe Seat and Metal Seat)	Graphite	Graphite
23	Mounting Plate	ASTM A516 Gr. 70 ASTM A240 Ss304 Steel	ASTM A240 SS316/ SS316L
24	Counter Sunk Screw	ISO 3506 A4-70	ISO 3506 A4-70

*Other materials are available on request.

**Recommended spares.

Gland Packing/Cover Gasket MOC is dependent on application service.

#CL 150 only.

STANDARD MATERIALS OF CONSTRUCTION

DOUBLE FLANGED (2" to 48")

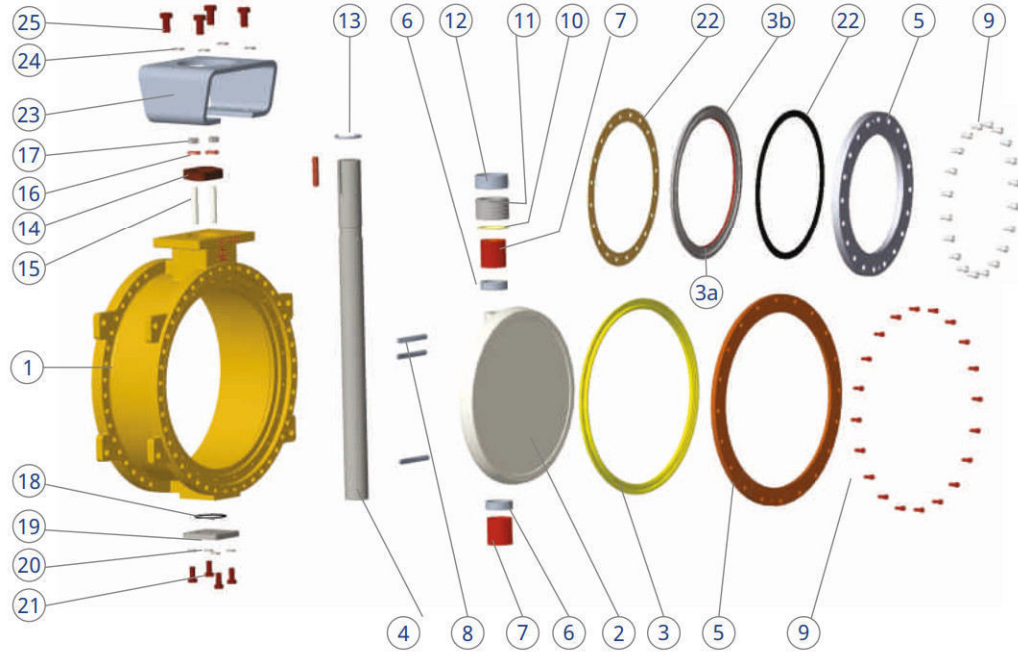

Part List

Item	Description	Standard Materials*	
		Carbon Steel	Stainless Steel
1	Body	ASTM A 216 WCB/WCC, ASTM A 352 LCC	ASTM A 351 CF8M/CF3M
2	Disc	ASTM A 351 CF8M/CF3M	ASTM A 351 CF8M/CF3M
3**	Seat (Soft)	PTFE#/ULTRA/RPTFE/UHMWPE	PTFE#/ULTRA/RPTFE/UHMWPE
3a**	Seat (Fire-Safe)	ASTM A 240 SS316 + ULTRA	ASTM A 240 SS316 + ULTRA
3b**	Seat (Metal)	ASTM A 240 SS316	ASTM A 240 SS316
4	Stem (Soft Seat)	ASTM A 322 4130 + ENP ASTM A 479 SS410 -cond. 3 ASTM A 564 Type 630 (17-4PH)	ASTM A 564 Type 630 (17-4PH) ASTM A 479 XM19 ASTM A 479 SS316 Strain Hardened Level 2
	Stem (Fire-Safe Seat)	ASTM A 479 SS410 -cond. 3 ASTM A 564 Type 630 (17-4PH)	ASTM A 564 Type 630 (17-4PH) ASTM A 479 XM19
	Stem (Metal Seat)	ASTM A 564 Type 630 (17-4PH)	ASTM A 564 Type 630 (17-4PH) ASTM A 479 XM19
5	Seat Retaining Ring	ASTM A 516 Gr. 70 Steel	ATM A 240 SS316/SS316L ASTM A 240 SS304
6	Disc Spacer	ASTM A 479 SS316/SS316L	ASTM A 479 SS316/SS316L
7**	Bearing (Soft Seat)	Bear-X	Bear-X
	Bearing (Fire-Safe Seat and Metal seat)	Fireproof DFP-D1	Fireproof DFP-D1
8**	Wedge Key	ASTM A 564 Type 630 (17-4PH)	ASTM A 564 Type 630 (17-4PH) ASTM A 479 XM19 ASTM A 479 SS316
9	Retainer Screw	ISO 3506 A4-70 ASTM A 1082 TYPE 630 (17-4PH) ASTM A 193 Gr. B8M	ISO 3506 A4-70 ASTM A 1082 TYPE 630 (17-4PH) ASTM A 193 Gr. B8M
10	Packing Spacer	ASTM A 479 SS316/SS316L	ASTM A 479 SS316/SS316L

Item	Description	Standard Materials*	
		Carbon Steel	Stainless Steel
11**	Gland Packing	PTFE (CHEVRON V- RING)/Graphite	PTFE (CHEVRON V- RING)/Graphite
12	Gland	ASTM A 479 SS316/ SS316L	ASTM A 479 SS316/ SS316L
13**	Stem Retainer	ASTM A 313 SS302	ASTM A 313 SS302
14	Gland Flange	ASTM A 516 Gr. 70 ASTM A105 ASTM A216 WCB Steel	ASTM A 240 SS316 ASTM A 351 CF8M ASTM A182 F316
15	Stud	ASTM A 193 Gr. B7 ASTM A 193 Gr. B7M ASTM A 193 Gr. B8M	ASTM A 193 Gr. B8M ASTM A 1082 TYPE 630 (17-4PH)
16**	Belleville Spring	ASTM A 666 SS 304	ASTM A 666 SS 316
17	Hex Nut	ASTM A 194 Gr. 8M ASTM A 194 Gr. 2H ASTM A 194 Gr. 2HM	ASTM A 194 Gr. 8M ASTM A 1082 TYPE 630 (17-4PH)
18**	Cover Gasket	PTFE/Graphite	PTFE/Graphite
19	Bottom Cover	ASTM A 516 Gr. 70 ASTM A 240 Ss304 Steel	ASTM A 240 SS316/ SS316L
20	Spring Washer	ASTM A 580 SS304	ASTM A 580 SS304
21	Hex Hd Screw	ISO 3506 A4-70 ASTM A 193 Gr. B7 ASTM A 193 Gr. B7M ASTM A 193 Gr. B8M	ISO 3506 A4-70 ASTM A 1082 TYPE 630 (17-4PH) ASTM A 193 Gr. B8M
22**	Seat Gasket (Fire-Safe Seat and Metal Seat)	Graphite	Graphite
23	Bracket	Steel ASTM A 240 SS304	ASTM A 240 SS316/ SS316L
24	Spring Washer	ASTM A 240 SS304	ASTM A 240 SS304
25	Hex Hd Screw	ISO 3506 A4-70	ISO 3506 A4-70

*Other materials are available on request.

**Recommended spares.

Gland Packing/Cover Gasket MOC is dependent on application service.

#CL 150 only.

Pressure Temperature Ratings

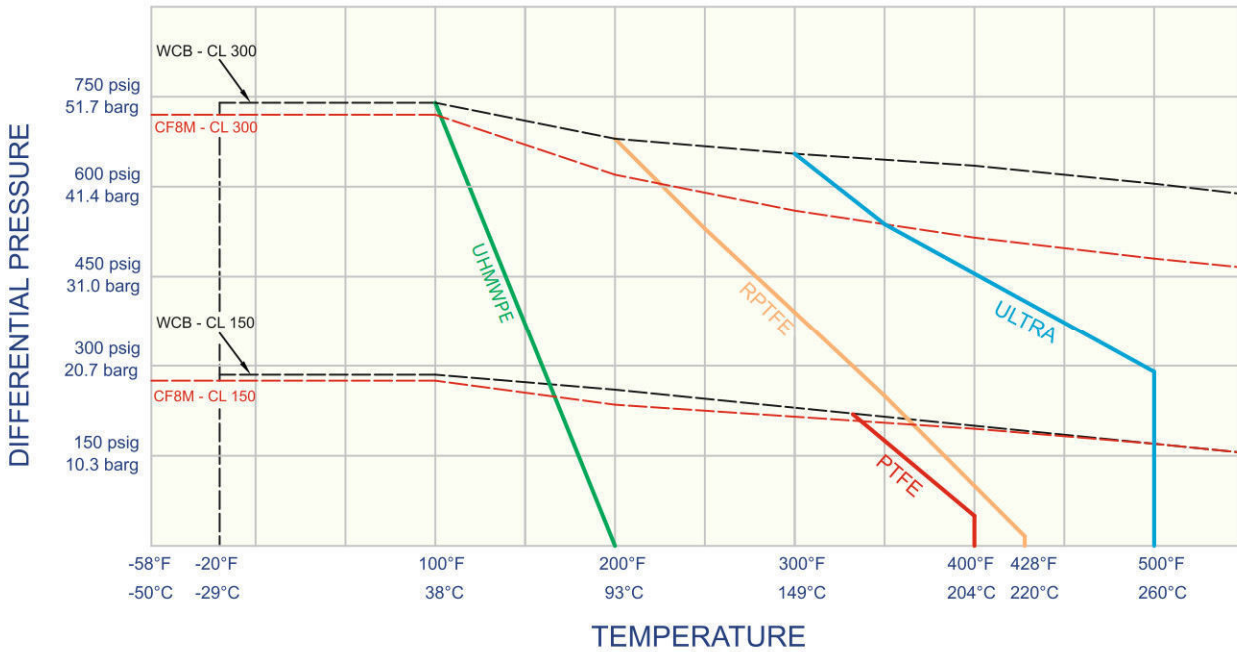

ULTRA Seat

An engineered fluorocarbon polymer that is rated for 500 °F at 285 psig. Excellent for handling aggressive fluids at high pressures, ULTRA is recommended for extended service in hostile environments involving chemical, thermal, and mechanical stress. ULTRA has excellent thermal stability and is ideal for steam, hot gases, and a variety of process chemicals where service can also be subject to pressure cycling.

Temperature Limits*

		Lower Limit	Upper Limit
		Deg F	Deg F
BODY	WCB	-20	800
	LCB	-50	650
	CF8	-320	1000
	CF8M	-320	1000
SEAT	PTFE	-58	400
	RPTFE	-58	428
	ULTRA	-58	500
	UHMWPE	-20	200

*Pressure-temperature rating shall be lesser of the shell rating or the seat rating.

Operator Information



All valves can be mounted with pneumatic actuators or electric actuators and accessories for complete on-off automation or modulating control. Valves can be also mounted with manual overrides.



Valves of all sizes can be direct mounted with gear operators for manual operation. Gear operators can also be attached with chain-wheel operators to open or close valves located on pipelines at high elevations.



Valves can be supplied with lever handles for manual operation. Optional accessories for hand-lever operation can be provided for various flow control requirements. Pad-lock can also be provided to prevent unauthorized operation.

100% TESTING 100% SERIALIZATION



CERTIFICATES



W.T. Maye, Inc. (WTMI)
1-877-705-9864
info@wtmi-usa.com
www.wtmi-usa.com

