

PIPE STAND SKIN SENSORS

#1	SUPPORT STRUCTURE				
4W	Weld pad support structure				
#2	SENSOR TYPE				
	THERMOCOUPLE		RTD (class A, Pt100)		
E	Type E	N	Type N	2	2-wire
J	Type J	T	Type T	3	3-wire
K	Type K			4	4-wire
X	Other, specify				
#3	PROBE DIAMETER				
B	1/4" Ø (0.250")		D	1/8" Ø (0.125")	
C	3/16" Ø (0.188")		X	Other, specify	
#4	PAD / SHEATH MATERIAL				
K	316 SS		M	Inconel 600	
H	304 SS		X	Other, specify pad & sheath*	
J	310 SS				
#5	TIP / WELD PAD DESIGN				
A	JMS Fastrax weld pad assembly, replaceable				
B	Weld pad, standard 1" x 1"				
C	Clamp hook pad (High temp Inconel 600 not available)				
D	Standard round tip				
E	Fastrax replacement "foot" only				
F	UniQersal weld pad				
G	Contoured weld pad (Contour matches #8 pipe diameter)				
X	Other, specify				
#6	N LENGTH		SEE ILLUSTRATION		
"	Specify (in inches)		3 1/2" minimum		

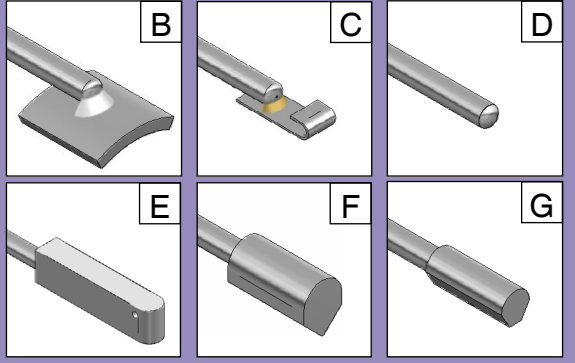
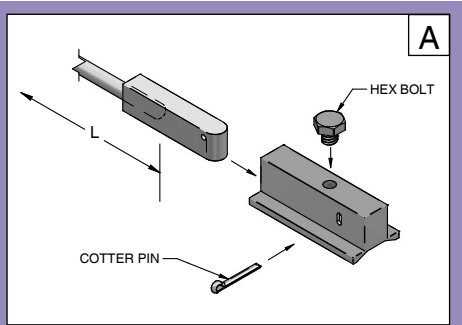

* Carbon steel pads usually welded to 316 SS sheath. F grade pads (ex: F11, F91) to I600 sheath.

Note: Standard mounting base pad material is 316SS. Add "1" prefix for matching mounting base pad material.

#7	JUNCTION STYLE		
G	Grounded	GROUNDED	UNGROUNDED
U	Ungrounded (RTDs always ungrounded)	GROUNDED	UNGROUNDED
I	Isolated	GROUNDED	UNGROUNDED

#8	CUSTOMER PIPE DIAMETER				*Weld pads are not curved to fit customer's pipe for diameters 12" and larger due to the minimal tangency gap.
	Standard Pipe size	Actual Ø	Standard Pipe size	Actual Ø	
075	3/4" (MIN)	1.05"	50	5"	5.56"
10	1"	1.32"	60	6"	6.63"
15	1 1/2"	1.90"	80	8"	8.63"
20	2"	2.38"	100	10"	10.75"
25	2 1/2"	2.88"	120*	12"	12.75"
30	3"	3.50"			
40	4"	4.50"			
X*	Other, specify				

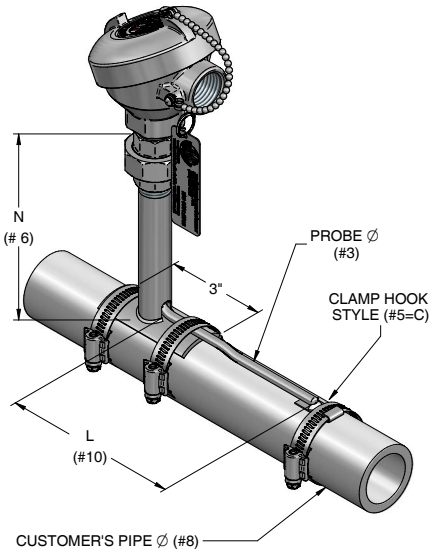

Choose "8PA" in selection #9, for a NEMA 4X housing w/ an easy to read digital indicator. N length specified must be sufficient to meet transmitter's maximum ambient temperature rating of 85 deg C.

#9	COLD END TERMINATION [Additional options see Pg 1-7]		
8PA*	Aluminum w/ viewing port, NEMA 4X, FM, CSA, ATEX, IECEx	A	Bare ends
M	Aluminum w/ screw cover & chain	X	Other, specify
I	Aluminum, NEMA 4X, FM, CSA, IP68		
SS	316 SS w/ screw cover & chain		
	* Includes indicating transmitter. See 8-2 for details		
#10	L LENGTH	SEE ILLUSTRATION	
"	Specify (in inches)	4" minimum	
Z	(no length) Spring loaded to pipe inside nipple		
#11	OPTIONS		
H	Hose clamps(QTY 3)	M	MTR (Welded parts)
S	SS tag	X	Other, specify

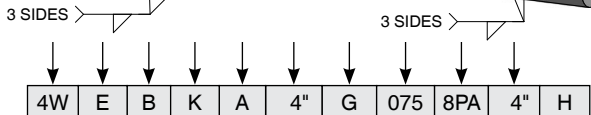

Note: Sensor weld pad styles A & D (#5) along with nipple stand weld pads will be curved to fit customer's pipe diameter (#8).

FASTTRAX

(Also referred to as the Removable Weld Pad design)

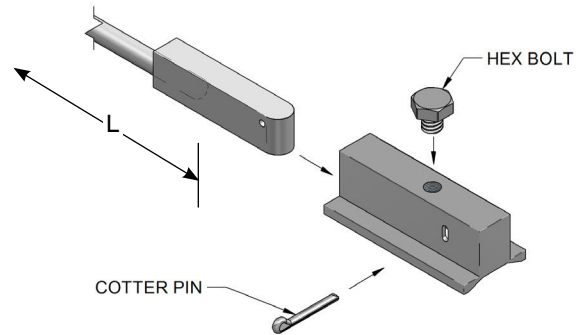
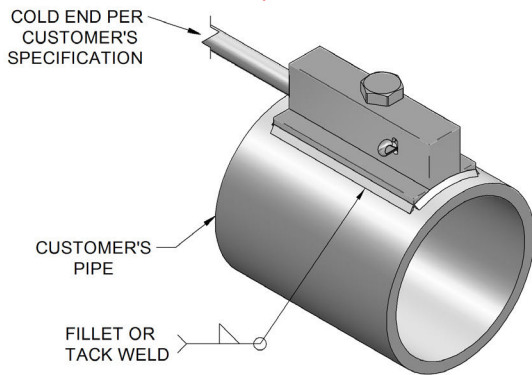

Note: To order this style as a thermocouple, see page 1-1, selection #6, options N and O in the JMS Ordering Catalog. For an RTD, see page 3-1, selection #4, option O.

APPLICATIONS

- Single or dual fired furnace tubes
- Top, side, or bottom fired furnace tubes
- Boiler tubes in power plants
- Catalyst tubes/tube sheath reactors (example: steam methane reformers, polygas units, acrylic acid units)
- Steam tracing lines
- Coker units
- External skin temperature for hydroprocessing units (example: hydrocracking, hydrotreating reactor)

INSTALLATION

- Installation or supervision available
- Supervision recommended
- Never burn up a thermocouple on install again
- E&I Tech can replace Fasttrax probe using only a ladder and a pair of pliers

LOW-COST REPLACEMENT

- Install hardware **ONE TIME**
- No need to scaffold furnace
- No grinding off existing TSTC
- No grinding down to base metal for welding (causes additional tube thinning)
- No welders necessary
- No moving Tubeskin TC out of the initial zone you want to measure because you cannot weld near last Tubeskin TC
- Re-order **ONLY** the replaceable probe

DESIGN

- Anti-slip cotter pin design
- Low profile heat shield
- Heavy-walled sheath
- Available in wrap-around design & parallel designs
- Available with S-Loops or expansion coils

HIGH RELIABILITY

- Fully protected probe
- S-Loops keep thermocouple sheath hidden and out of flame
- Clips placed on tube help hold thermocouple in place while process acts as a heat sink
- Wire contact **WON'T** slip from contact point due to JMS cotter pin design
- Safety
- Measure tube temperature, not process temperature
- Recognize tube wear and tube thinning
- Error set to high side of tube temperature-added safety
- Small offset allows you to push process furnace without sacrificing safety
- Highly accurate for safety
- Ceramic-filled heat shields may lead to low tube skin reading and compromise safety
- Large metal heat shields can absorb large amounts of radiant heat

HIGH ACCURACY

- High accuracy bare wire contact with tube surface
- Bare wire is the standard by which all tube skin thermocouples are tested for accuracy
- Low heat transfer from heat shield/lowest profile heat shield in the industry
- Reduces effects of radiant heat on thermocouple