

JMS will generate a drawing specific to your order!

GENERAL NOTES

- 1) - BREAK AND DEBURR ALL SHARP EDGES.
- 2) - STAMP TAG# BELOW ARROW (1/4" TEXT).
- 3) - LASER ETCHED TAGGING DATA.

TESTING AND DOCUMENTATION REQUIREMENTS:

- A. EXTERNAL HYDROSTATIC PRESSURE TEST TO 2175 PSIG @ AMBIENT FOR 15 MINUTES. WHEN PERFORMING TEST, VALVE (ITEM #3) NEEDS TO BE PLUGGED. (AFTER CUTTING TIP).
- B. INTERNAL HYDROSTATIC PRESSURE TEST TO 2175 PSIG @ AMBIENT FOR 15 MINUTES. (BEFORE CUTTING TIP).
- C. LIQUID DYE PENERANT INSPECT ALL WELDS.
- D. POSITIVE MATERIAL IDENTIFICATION W/ CARBON CONTENT FOR VALVE (ITEM #3), BAR (ITEM #1), FLANGE (ITEM #2), AND WELD.
- E. WAKE FREQUENCY CALCULATIONS.
- F. MILL TEST REPORTS FOR BAR (ITEM #1), FLANGE (ITEM #2), VALVE (ITEM #3), & WELD.
- G. 100% RADIOGRAPHY PER ASME B31.3 (NORMAL SERVICE). RADIOGRAPHY TO BE DONE PRIOR TO WELDING VALVE ON.

FOR CUSTOMER APPROVAL	
DATE:	_____
INITIALS:	_____

ARROW STAMPED ON COLD SIDE OF FLANGE INDICATES FLOW DIRECTION

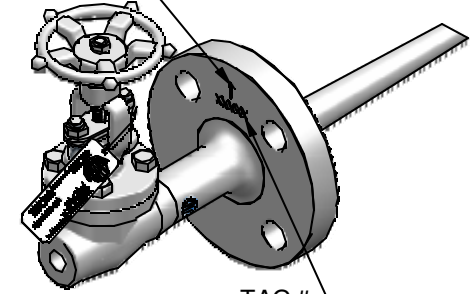

TAG # (SEE NOTE 2)

↑
FLOW DIRECTION

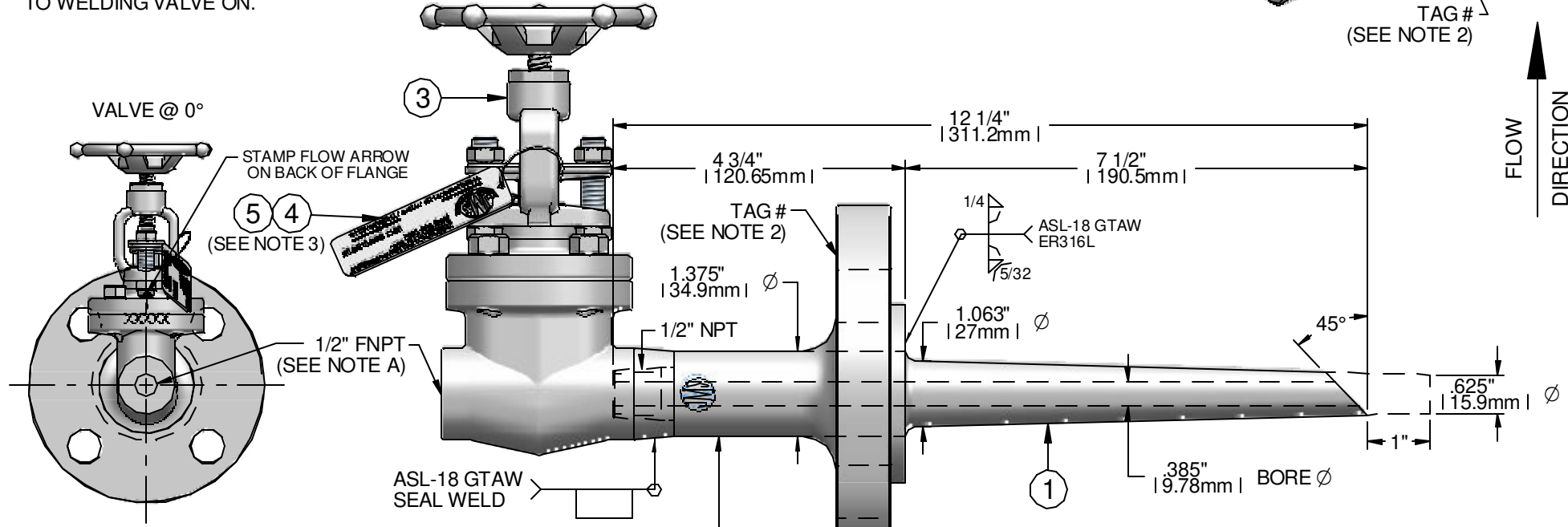

TAGGING DATA:
TAG #. 7AA013E
SERVICE: (DO)
HEXENE DRYER OUTLET

STAMPING
"A"
MATERIAL
BAR #
TAG #

JMS SOUTHEAST INCORPORATED CERTIFIES THIS DRAWING IS IN ACCORDANCE WITH JMS SOUTHEAST INCORPORATED ENGINEERING SPECIFICATIONS AND ACCURATELY REPRESENTS THE EQUIPMENT FURNISHED. THIS DRAWING IS THE SOLE PROPERTY OF JMS SE, AND MUST BE RETURNED UPON DEMAND. IT MAY NOT BE REPRODUCED NOR THE INFORMATION CONTAINED THEREIN USED WITHOUT THE WRITTEN PERMISSION OF JMS SOUTHEAST INCORPORATED.

Company Name: JMS Southeast, Inc.		Project Name:	
CUST. DRAWING:		Reference Data:	
SHT. NO. REV. NO.		QT#:	
Drawing #:		ERF #:	
Rev 00		pg 1 of 1	

#	DESCRIPTION
1	CUSTOM SAMPLE THERMOWELL, FLANGED, 1 1/2" 600# RF (FULL PEN. WELD) F316LSS B16.5 SA-182, TAPERED (1.063" TO .677") W/ 45° OPEN TIP, MALE 1/2" NPT, .385" BORE, 316SS SA-479
2	FLANGE, BLIND, 1 1/2", 600#, RF, (FULL PEN. WELD), F316L SS B16.5 SA-182
3	GATE VALVE, 1/2" FNPT X 1/2" FNPT, 1500# STANDARD PORT, F316L SS (BONNEY FORGE: 9HL-18L-T)
4	JMS TAG, SS
5	WIRE SEAL, SS WIRE WITH LEAD DISC

Approvals	Initials	Date
Drafting		
Engineering		
Second		

JMS SOUTHEAST, INC.
Temperature Measurement
105 Temperature Lane
Statesville, North Carolina 28677
Phone: (704) 873-1835
Fax: (704) 878-6166
www.jms-se.com
Email: sensors@jms-se.com

REV. 4-10-2009