

# 3-A CERTIFIED SANITARY WELD-IN THERMOWELLS

JMS Southeast, Inc. is proud to be a US manufacturer of a full line of sanitary RTDs, thermocouples and thermowells (3-A Authorization #1482).

JMS Southeast's 3-A certified weld-in thermowells are designed to be used with either sanitary 3-A certified probes\* or non-certified probes.\*\* Sanitary thermowells should be welded to a tank or a vat with a full crevice-free fillet weld to avoid cracks and crevices. Standard sanitary weld-in wells are fabricated from stainless steel and then polished to a #4 finish.\*\*\*



In addition to weld-in thermowells, JMS also offers a full line of 3-A certified sanitary cap thermowells. Illustrations of the most commonly selected cap styles can be found on page 4-2, row 8 of this catalog.

- \* For ordering and additional information, see pages 4-1 through 4-3 of this catalog.
- \*\* For thermocouples, please refer to section 1 of this catalog. For RTDs, please refer to section 3.
- \*\*\* Other finishes available upon request to meet customer requirements.

#1	DESCRIPTION										
5C	3-A Certified sanitary thermowells - Add "W" here for a plug with a chain attached to well. (Example: 5CW)										
	#2	U (INSERTION) DEPTH [15]									
		U__"	Specify length in inches. <span style="color: red;">Note: When specifying spring-loaded replacement sensor, customer should specify immersion length 1/4" shorter than the overall weld-in thermowell length</span>								
		#3	MATERIAL <span style="color: red;">Note: see page 5-1 for more options.</span>								
			H	304 SS	K	316 SS	X	Other, specify	Note: When specifying an X, material selected must comply with 3-A standard, 74-03		
			I	304L SS	L	316L SS					
		#4	BORE SIZE & SENSOR CONNECTION insert 1/2" NPSM.								
			2	.260" ID	3	.385" ID	X	Other, specify	Add "N" for FNPT (Example: 2N=FNPT)		
		#5	T (LAG) EXTENSION [5-15]								
			Z	N/A (No Lag)				T__"	Specify length in inches		
		#6	TAGGING OPTIONS								
			1	Stamped on well (Standard)							
			X	Other							
			Z	N/A							
		#7	DOCUMENTATION & CERTIFICATIONS -- use all that apply (Example: "DU" requests dye penetrant test & X-Ray examination)								
			M	Material Test Reports (MTR)				E	Certificate of electropolish		
			D	Dye penetrant testing				A	Certificate of No Animal		
			P	Internal hydrostatic pressure test				N	Derived Material (ADM)		
			U	X-Ray examination				O	Certificate of no polishing compounds		
			W	Premium SwiftyCalc ASME 19.3TW calculation				Certificate of cleaned for Oxygen service			
			S	Surface finish certificate							

Note: Standard (sensor) connections are 1/2" FNPSM (female straight) to match 1/2" MNPT (male tapered)

Note: Does not include head and nipple. These parts may be ordered separately.

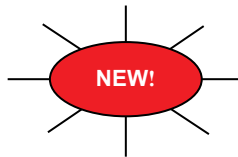
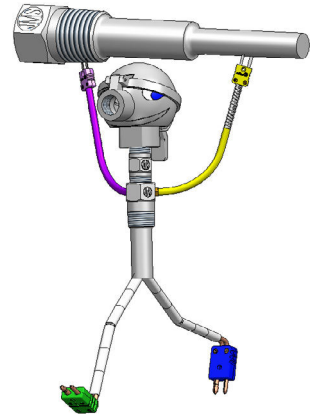
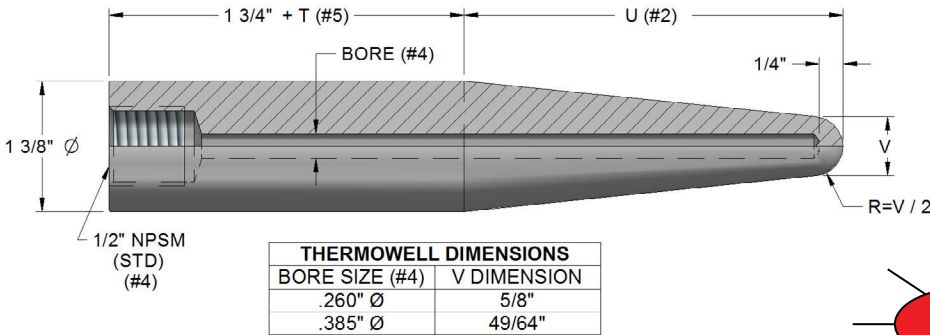

FREE Wake Frequency Calculations to ASME PTC 19.3 TW, [SwiftyCalc!](http://www.SwiftyCalc.com) Visit [JMS-SE.com](http://JMS-SE.com) to sign up today!  
[www.JMS-SE.com/SwiftyCalc](http://www.JMS-SE.com/SwiftyCalc)

