

# INDUSTRIAL AND MINIATURE THERMOCOUPLES

#1	DESCRIPTION [6, 7]
1	Thermocouple
#2	TYPE [8,9,10]
	J,T,K,E,N,X (Other, Specify)
#3	LIMITS OF ERROR/ELEMENT CONSTRUCTION
1	Standard Single 6 Standard Triple
2	Standard Dual X Other, specify
3	Special Single
4	Special Dual

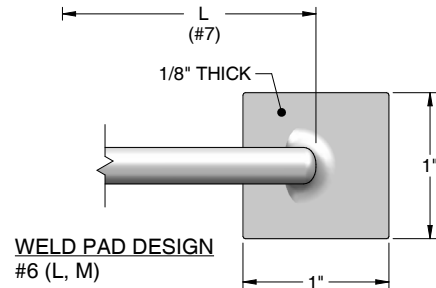

WELD PAD DESIGN #6 (L, M)

Many more options available at [JMS-SE.com](http://JMS-SE.com)

**Note:** For hollow tube sensors or sensors requiring a factory bend, see pages 2-1 and 2-2.

[ ] Brackets indicate page numbers where additional helpful information can be found in technical catalog. Now available online at [www.JMS-SE.com/TechnicalCatalog](http://www.JMS-SE.com/TechnicalCatalog)

#4	OUTSIDE DIAMETER [1-11]			CONDUCTOR SIZE (FOR BASE METALS ONLY)							
	OD	Single	Dual	OD	Single	Dual	OD	Single	Dual		
P	1/2"	10	12	R	6mm	16	18	F	1/25"	32	34
A	3/8"	13	16	C	3/16"	19	20	X*	Other, specify		
Y	5/16"	14	16	D	1/8"	22	24	*JMS now offers sheath as small as 0.010" diameter			
B	1/4"	16	18	E	1/16"	28	30				

#5	SHEATH MATERIAL [11]	MAX °F [2-8, 4-17]	MAX °F
H	304 stainless steel	1650	C Teflon coated stainless steel 400
J	310 stainless steel	2100	S Titanium 400
V	STABALOY	2220	Q Hastelloy C-276 800
K	316 stainless steel	1650	P Pyrosil 2300
M	Inconel 600	2100	X Other, specify

#6	MEASURING JUNCTION [1-12, 13, 14, 15]		
G	Grounded	P Reduced tip, grounded	
U	Ungrounded	Y Reduced tip, ungrounded	
E	Exposed (isolated on dual/triple)	R Gas/air, exposed	
I	Isolated	S Gas/air, grounded	
J	Pointed tip, grounded 45°	T Gas/air, ungrounded	
K	Pointed tip, ungrounded 45°	V* Enlarged tip, grounded	
L	Weld pad, grounded (Flat)	W* Enlarged tip, ungrounded	
M	Weld pad, ungrounded (Flat)	X Other, specify	
N	Weld pad, removable grounded	*Provide length and enlarged diameter description when selecting these options.	
O	Weld pad, removable ungrounded	<b>Note:</b> For options N, NF, O, & OF Fastrax (aka removable weld pad) designs, refer to 4-11.	
NF	Removable, "foot" only, grounded		
OF	Removable, "foot" only, ungrounded		

REDUCED TIP DESIGN #6 (P,Y)

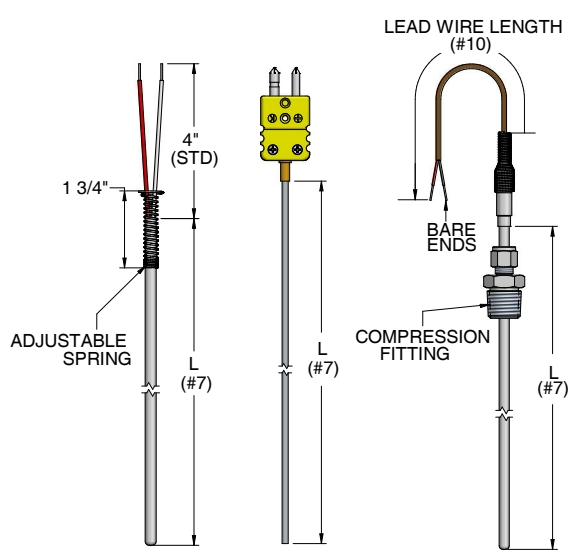
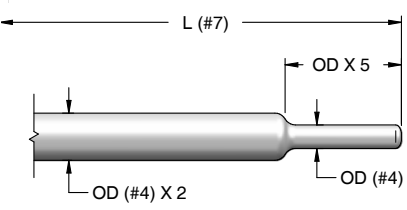

**Note:** L is the overall length of the sensor to the transition, wire, plug, head, or fixed attaching device. L excludes non-fixed attaching devices.

#7	LENGTH (See illustrations on page 1-1 through 1-3 for lengths)
"	Length in Inches (Lengths greater than 90" may be coiled for shipment)

**NEW** Skip to page 1-3 to complete selection #8 if your sensor requires a nipple and/or union extension.

#8	STANDARD INDUSTRIAL ATTACHING DEVICE [1-3, 6-13]	
X	Other, specify	
Z	N/A	No attaching device
G	Single thread (process)	Welded design
F	Single thread (reversed)	
W	Double threaded	
H*	SS w/ SS ferrule	Compression design
I*	SS w/ Teflon ferrule	
J*	SS w/ Lava ferrule	
K*	SS w/ Nylon ferrule	
L*	Brass w/ Brass ferrule	
D	Single threaded (process)	Spring-loaded design
C	Double threaded w/ oil seal	
A	Double w/ threaded retainer	
E	Adjustable spring	
S	Double threaded (most common)	
B	Double threaded Bayonet	
BS*	Double threaded Bayonet w/ oil seal	
BD	Single threaded Bayonet	
BDS*	Single threaded Bayonet w/ oil seal	

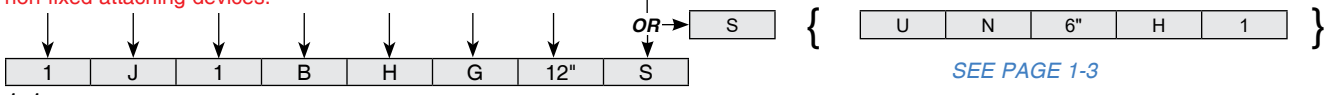

# INDUSTRIAL AND MINIATURE THERMOCOUPLES

#9	PROCESS CONNECTION SIZE & TYPE [1-3]	<b>Note:</b> Threaded bushing may be used for sizes larger than 1/2" NPT			
L M A P	1/8" NPT 1/4" NPT 3/8" NPT 1/2" NPT (Standard) w/ symbols W,S,C, & N from selection #8	O J T Y	3/4" NPT 1" NPT 1 1/4" NPT 1 1/2"NPT	X Z	Other, specify N/A

#10	LEAD WIRE TYPE & LENGTH IN INCHES [SEE SECTION 7]				
Z 1__" 2__" 3__" 4__" 5__"	No lead wires Fiberglass braid PVC Teflon Hi-temp fiberglass braid Kapton	}	Solid 20 AWG	7__" 8__" S9__" X__"	Bare wire (AWG per #4) PVC coil cord (Relaxed length) (4" standard length for in head bayonet sensors) Teflon ultra premium Type T, stranded 22 AWG Other, specify
<b>Note:</b> Add an S prefix to your selection to designate stranded wire. Preferred for high vibration applications with lead wires > 6". Example: S312= 12" stranded Teflon lead wire. 24 AWG or smaller may be used to accommodate some smaller diameters and flex armor extensions.					

#11	ARMOR OR HEAT SHRINK [7-7,16] <span style="float: right; color: red;">A special armor adapter is used when flex armor is longer than 60".</span>			
A B C D F G H	SS flex armor SS flex armor teflon coated white SS flex armor teflon coated black Small 1/8" ID SS flex armor SS overbraid Heat shrink/sleeving Jacket to match primary insulation	J Z K X	Aluminum mylar shielded and jacketed to match primary insulation N/A SS overbraid, drain, & yellow Teflon jacket overall, 20 AWG stranded (Type K only) Other, specify	

#12	TYPE OF TRANSITION [1-16]			
H S T R X Z	Heat shrink Size on size 3/8" OD (Standard) 1/4" OD Other, specify No transition	<b>Note:</b> For high humidity/moisture environments (< 500°F), put a 2 after your selection. For example, R2.  <b>Note:</b> For high temperatures at the transition area (500°F - 1200°F), put a 3 after your selection. For example, T3.		

#13	COLD END TERMINATION Choose as many as applicable (Additional options see Pg. 1-7) (Visit our online catalog for additional terminations, <a href="http://www.JMS-SE.com/ends">www.JMS-SE.com/ends</a> )			
Connectors		Heads [6-1] visit <a href="http://www.JMS-SE.com/headspecs">www.JMS-SE.com/headspecs</a>		
B C F WM D E G WF	Miniature plug Standard plug High temperature plug (< 800°F) Microphone style plug (6DA) Miniature jack Standard jack High temperature jack (<800°F) Microphone style jack (6DA)	Exp. Proof	I J P SI	Aluminum, NEMA 4X, FM, CSA, IP68 (6IA) 316 SS, NEMA 4X, FM, CSA, IP68 (6ISS) Aluminum, NEMA 4X, FM, CSA, ATEX, IECEx, IP68 (6IAIEC) Cast Iron, NEMA 4, UL, CSA (6I)
Transmitters		Gen. Purpose	L M R N Q SS	Aluminum w/ hinged cover (6L) Aluminum w/ screw cover & chain (6M) Aluminum w/ hinged high dome cover (6R) Cast Iron w/ screw cover (6N) Black plastic (6Q) 316 SS w/ screw cover & chain (6SS)
8H 8N 8I 8E 8D 8PS 8PA	Isolated transmitter Non-isolated transmitter Hart protocol Intrinsically safe Hart/intrinsically safe Indicating with SS Exp. housing Indicating with Alum Exp. housing	<b>Note:</b> Add span range after transmitter selection. Example: 8H(0-200C). Transmitter output=4-20mA. (See section 8 for other options).		
		Other		
		A K O X	Bare ends Spade lugs (6SL) Open terminal block (6B4) Other, specify	

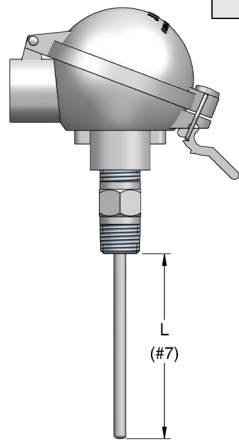

**Note:** L is the length of the sensor to the fixed attaching device.

LEAD WIRE LENGTH (#10)

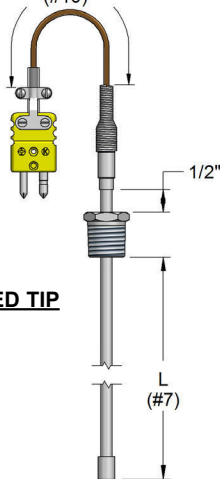

**ENLARGED TIP**  
#6 (V,W)

#14	OPTIONS Use only if applicable [INTRODUCTION]		
Marking / Tagging		Certifications	
1 2 3 4 7 T	Stainless steel tag Plastic tag Paper tag Laser etch on probe CE marking [page XV] Calibration Tag	5 5L* 5M 6** 6L	Calibrate at specified point(s). Corrections data provided for each point. Standard lot calibration Material calibration report. Premium calibration report. Corrections data will be provided for temperatures within the range. Premium lot calibration report. Corrections data will be provided for temperatures within the range.
		8*** M	Guide 17025 calibration certification MTR (sheath / tubing / measuring junction components)
		Other Options	
		B S X	Head mounting bracket Ship straight (Do not coil) Other, specify
* AMS 2750D/E/F compliant ** Must specify increments & range (Example: 0 to 300°F, 10° increments) *** Must choose calibration option other than 5M			

## COMPLETE PART NUMBER EXAMPLES

- With nipple-union-spring-loaded extension assembly: **1J1BHG12"S[UN6H1]PZZZL1**
- Without extension assembly: **1J1BHG12"SPZZZL1**

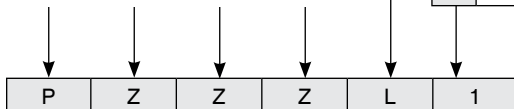

# CUSTOM NIPPLE/UNION EXTENSION CONFIGURATOR

An extension assembly provides extra length extending the sensor head past insulation and away from heat. Standard unions are 1/2" FNPT on both ends. The union joins two nipples in an extension assembly and has a standard pressure rating of 150 PSIG.

When a nipple-union-nipple assembly is selected and spring-loading of the thermocouple element is required, there are two different methods of spring-loading the sensor. JMS's standard, recommended method is to use the machined 1/2" x 1/2" NPT spring-loaded stainless steel fitting as one of the nipples. With this design, the probe is secured within the fitting and mounted to the head in a rigid manner instead of spring-loading against a terminal block, as is the case with a standard nipple-union-nipple. Due to stress exerted by spring, selection #8, option N "nipple" should never be used with an in-head transmitter. Any of the other options within option #8 are compatible with in-head transmitters.

**Notes:**

- The standard JMS spring designed specifically for a 1/4" OD sensor is made of high nickel proprietary spring wire which allows users to successfully maintain 1/2" of spring-loading even up to 1000°F.
- Spring-loaded extension assemblies should not be used with ceramic protection tubes.

		#8	COLD SIDE STANDARD INDUSTRIAL ATTACHING DEVICE [1-3, 6-13]		
		X	Other, specify		<p>STANDARD ATTACHING DEVICE (ALREADY SELECTED IN #8)</p>
		G	Single Thread (Process)		
		W	Double Threaded		<p>MOST COMMON</p> <p>** L is the overall length of the sensor to the fixed attaching device. Page 1-1, selection #7 for T/Cs or 3-1, selection #6 for RTDs.</p>
		H2	SS w/ SS ferrule		
		I2	SS w/ Teflon ferrule		
		J2	SS w/ Lava ferrule		
		K2	SS w/ Nylon ferrule		
		L2	Brass w/ Brass ferrule		
		D	Single threaded		
		C	Double threaded w/ oil seal		
		A	Double w/ threaded retainer		
		N	Nipple (spring-loaded against terminal block)		
		S	Double threaded		
		B	Double threaded Bayonet		
		BS	Double threaded Bayonet w/ oil seal		
		BD	Single threaded Bayonet		
		BDS	Single threaded Bayonet w/ oil seal		
		#8.1 UNION		<p>UNION (#8.1)</p>	
		U	Union		
		O	Coupling		
		X	Other, specify		
		<b>Note:</b> Thread adapters may be used when symbol #9 is not 1/2" NPT.			
		#8.2 PROCESS FITTING (MALE)		<p>PROCESS FITTING (#8.2)</p>	
		N	Nipple		
		X	Other, specify		
		Z	N/A (female thread)		
		<b>Note:</b> Thread adapters may be used when symbol #9 is not 1/2" NPT.			
		#8.3 N LENGTH		<p>N (#8.3)</p>	
		"	Specify (Inches)*		
		Z	N/A (female thread)		
		<b>* ONLY for configurations with nipples (option N for selection #8 or #8.2) ALL other configurations have fixed lengths and this selection is not applicable.</b>			
		#8.4 UNION and/or NIPPLE MATERIAL		<p>H 304 stainless steel <input type="checkbox"/> X Other, specify</p> <p>K 316 stainless steel</p> <p>C Black steel</p> <p>G Galvanized steel</p>	
		H 304 stainless steel			
		K 316 stainless steel			
		C Black steel			
		G Galvanized steel			
		#8.5 UNION PRESSURE RATING		<p>1 #150 - A351 spec (Standard) } ASTM</p> <p>2 #3000 - A182 spec</p> <p>3 #6000 - A182 spec</p> <p>X Other, specify</p>	
		1 #150 - A351 spec (Standard)			
		2 #3000 - A182 spec			
		3 #6000 - A182 spec			
		X Other, specify			

**Note:** High nickel proprietary spring material is rated to 1000°F. (For 1/4" Ø sensors)

S { U N 6" H 1 }

Continue on to the "PROCESS NPT" selection to finish creating your sensor part number. Selection #9 on page 1-2 (thermocouples) and 3-2 (RTDs).

# ADDITIONAL TERMINATIONS

**COLD END TERMINATION** [SEE SECTION 6] Choose as many as applicable (**JMS part number prefixes are shown in parenthesis**)

**Connectors**

<b>Plugs</b>		<b>Jacks</b>	
B	Miniature plug (6A1B)	D	Miniature jack (6A1D)
BH	Miniature high temperature plug (6A2B) <800°F	DH	Miniature high temperature jack (6A2D) <800°F
C	Standard plug (6A1C)	E	Standard jack (6A1E)
F	Standard high temperature plug (6A2C) <800°F	G	Standard high temperature jack (6A2E) <800°F
WM	Microphone style plug (6DA)	WF	Microphone style jack (6DA)
WA	Solid pin plug, heavy duty (6A3C)	WB	Solid pin jack, heavy duty (6A3E)
WC	Jab in plug (6A4C)	WD	Jab in jack (6A4E)
WE	Ultra high temperature plug, glazed (6A5C) <1200°F	WG	Ultra high temperature jack, glazed (6A5E) <1200°F
WH	Ultra high temperature plug, unglazed (6A7C) <1200°F	WI	Ultra high temperature jack, unglazed (6A7E) <1200°F
WJ	Low noise plug (6A6C) <425°F	WK	Low noise jack (6A6E) <425°F
WL	DIN-IEC microphone plug (6DB)	WN	DIN-IEC microphone style jack (6DB)
V	Molded/water resistant plug (6DC)	VF	Molded/water resistant jack (6DC)
Y	M12 Male connector (6DY)	YF	M12 Female connector (6DY)
WQ	Miniature locking plug (6A8B2)	WR	Miniature locking jack (6A1DL2)
WS	Standard plug, locking (6A8C2)	WT	Standard jack, locking (6A8E2)

**Heads** [6-1] Visit [www.JMS-SE.com/headspecs](http://www.JMS-SE.com/headspecs)

<b>Explosion Proof</b>	
I	Aluminum, NEMA 4X, FM, CSA, IP68 (6IA)
J	316 stainless steel, NEMA 4X, FM, CSA, IP68 (6ISS)
P	Aluminum, NEMA 4X, FM, CSA, ATEX, IECEx, IP68 (6IAIEC)
U	316 stainless steel, NEMA 4X, ATEX, IP68 (6ISSATEX)
SI	Cast Iron, NEMA 3, 4, UL, CSA (6I)
GA	Aluminum, screw cover w/ indicating window, NEMA 4X, ATEX, IECEx, FM, CSA, IP68 (688A1)
GS	316SS, screw cover w/ indicating window, NEMA 4X, ATEX, IECEx, FM, CSA, IP68 (688S1)

<b>General Purpose</b>	
L	Aluminum w/ hinged cover (6L)
M	Aluminum w/ screw cover & chain (6M)
R	Aluminum w/ hinged high dome cover (6R)
N	Cast Iron w/ screw cover (6N)
Q	Black plastic (6Q)
SS	316 stainless steel w/ screw cover & chain (6SS)
WP	White plastic, screw cover, Sanitary (6WP)
SB	Nickel plated, cylinder style, 1/4" NPT (6S250)
SD	Nickel plated, cylinder style, 1/8" NPT (6S125)
SC	Stainless steel, socket cap style
ST	Molded plastic, mini head, 1/4" NPT, < 350F (6T)
SU	Molded plastic, mini head, 1/4" NPT, < 800F (6U)

*Some applications may have pre-existing threaded pipes or protection tubes where no attaching device is needed to make sensor connection. In such a case, length will be measured from the base of the head.*

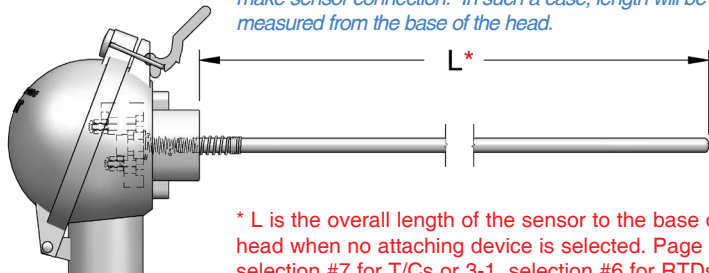

**\* L is the overall length of the sensor to the base of the head when no attaching device is selected. Page 1-1, selection #7 for T/Cs or 3-1, selection #6 for RTDs.**

**Transmitters [ 8-1 to 8-3 ]** **Notes:** - Add span range after transmitter selection. Example: 8H(0-200C).  
- Transmitter output = 4 - 20 mA. (See section 8 for other options).

8H	Isolated transmitter	8PA	Explosion proof, IP66/IP68, NEMA 4X, ATEX/IECEx, FM/CSA, Aluminum, threaded cap with glass viewing window, touch programmable [ 8-2 ]
8N	Non-isolated transmitter		
8I	Hart Protocol	8PS	Explosion proof, IP66/IP68, NEMA 4X, ATEX/IECEx, FM/CSA, 316 SS, threaded cap with glass viewing window, touch programmable [ 8-2 ]
8E	Intrinsically safe		
8D	Hart/Intrinsically safe		
8M	Integral transmitter (see page 3-5)		<b>RTDs ONLY</b>

**Other**

A	Bare ends		
K	Spade lugs (6SL)		
RL	Ring lugs (6RL)		
O	Open ceramic terminal block, brass screw terminal (6B)		
OA	Open Bakelite terminal block, nickel plated screw terminal (6BB)		
OB	Open ceramic terminal block for sensors with bayonet style connection, brass screw terminal (6B or 6C)		
OG	Ceramic terminal block, brass screw terminal (6G)		
OP	Pluggable polyimide terminal block, nickel plated screw terminal (6PT)		
OS	Open ceramic terminal block, nickel plated solder terminal (6C)		
CG	Cord connector/grip, aluminum 1/2" NPT (6CC)		
TB	Conduit bushing, 3/4" NPT male X 1/2" NPT female, plated steel (6IRB)		
X	Other, specify		

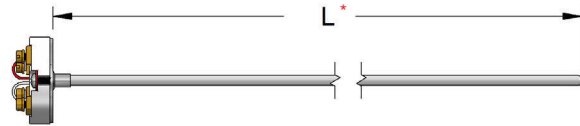

**\* L is the overall length of the sensor to the base of the terminal block mounting plate when open terminal block cold end termination is selected without a fixed attaching device. Page 1-1, selection #7 for T/Cs or 3-1, selection #6 for RTDs.**

# RESISTANCE TEMPERATURE DEVICES (RTDS)

#1	DESCRIPTION					
3	RTD					
#2	ELEMENT TYPE [3-4, 9, 10, 11, 15, 18, 22, 24]		100 Ω Platinum 0.00385 alpha (Ω/Ω°C) unless otherwise stated			
	Resistor Accuracy at 0°C		Thermometer Class [pg. 3-18]	Resistor Class [pg. 3-18]	<b>Note:</b> Wound or film resistors may be used. * For compliant results, use 4 wire RTD for high accuracy (types P & S).	
B	± 0.30°C (Competitor's Std)		B	≥ F 0.3		
E	± 0.15°C (Standard)		A	≥ F 0.15		
P*	± 0.06°C		AA	≥ 1/2 F 0.1		
S*	± 0.03°C (Best Accuracy)		1/4 A	≥ 1/10 W 0.3		
N	± 0.74°C (120 Ω Nickel α=0.00672)		Non-Standard	Non-Standard		
M	± 0.30°C (1000 Ω)		B	≥ F 0.3		
X	Other, specify [3-22]		--	--		
#3	ELEMENT CONSTRUCTION [4]					
S	Single	Standard construction	SV	Single	High vibration construction	
D	Dual	Standard construction	DV	Dual	High vibration construction	
J	Single	Swaged construction				
K	Dual	Swaged construction				
X	Other, specify					
	#4	TUBE DIAMETER	MUST CHOOSE 1	TIP CONSTRUCTION [1-13]	MUST CHOOSE 1	
	P	1/2" (.500")	D	1/8" (.125")	N	Normal, closed tip (Standard)
	A	3/8" (.375")	X	Other, specify	K	Pointed tip, 45°
	Y	5/16" (.313")	Z	N/A	M	Weld pad
	B	1/4" (.250")			O	Weld pad, removable
	R	6mm (.236")			R2	Gas/Air, exposed
	C	3/16" (.188")			W*	Enlarged tip
					Y2	Reduced tip
					X	Other specify

**Note:** Use swaged for high temperature, bendability, and/or longer than 90".

\* Provide length and enlarged diameter description when selecting this option.

[ ] Brackets indicate page numbers where additional helpful information can be found in our technical catalog. Now available online at [www.JMS-SE.com/TechnicalCatalog](http://www.JMS-SE.com/TechnicalCatalog)

#5	TUBE MATERIAL [3-11, 3-13]				
K	316 stainless steel	C	Teflon coated, stainless steel	X	Other, specify
L	316L stainless steel	S	Titanium		
M	I-600 (Use if symbol #7 >500°F)	Q	Hastelloy C-276		

#6	LENGTH (L) (See illustrations on pages 3-1 and 3-2 for "L" dimension)				
"	Immersion length in inches (lengths greater than 90" may be coiled for shipment)				

#7	MAX TEMPERATURE AT WHICH TIP WILL BE EXPOSED				
A	<0°C (32°F) Cryogenic = 5 Kapton				
B	<200°C (392°F) = 3 Teflon*				
C	<288°C (550°F) = 5 Kapton*				
D	<350°C (662°F) = 1 Fiberglass*				
E	<660°C (1220°F) = 4 High temperature fiberglass*				
	*If no transition (Z) is in symbol 13, we recommend these corresponding selections for primary wire insulation on hollow tube sensors.				

**NEW** Skip to page 1-3 to complete selection #8 if your sensor requires a nipple and/or union extension.

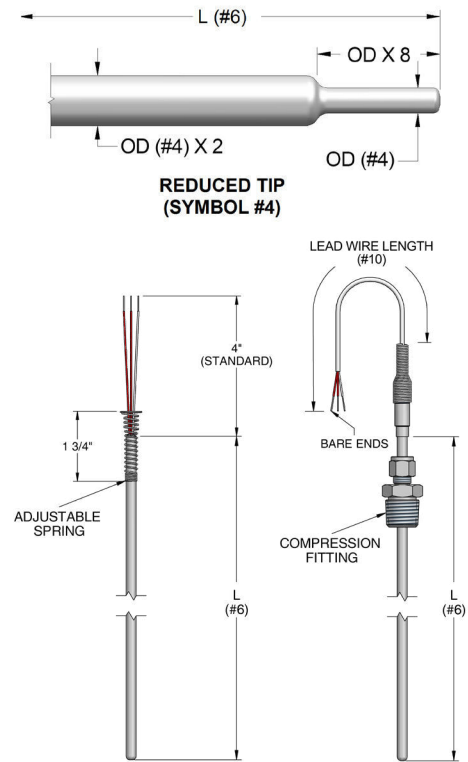

**Note:** L is the overall length of the sensor to the transition, wire, plug, head, or fixed attaching device. L excludes non-fixed attaching devices.

#8	STANDARD INDUSTRIAL ATTACHING DEVICE [1-3, 6-13]				
X	Other, specify				
Z	N/A	No attaching device			
G	Single thread (process)	Welded design			
F	Single thread (reversed)				
W	Double threaded				
H*	SS w/ SS ferrule	Compression design			
I*	SS w/ Teflon ferrule				
J*	SS w/ Lava ferrule				
K*	SS w/ Nylon ferrule				
L*	Brass w/ Brass ferrule				
D	Single threaded (process)	Spring-loaded design			
C	Double threaded w/ oil seal				
A	Double w/ threaded retainer				
E	Adjustable spring				
S	Double threaded (most common)				
B	Double threaded bayonet				
BS	Double threaded bayonet w/ oil seal				
BDS	Single threaded bayonet w/ oil seal				

3
E
S
BN
K
12"
B
S

OR → S
U
N
6"
H
1

SEE PAGE 1-3



# RESISTANCE TEMPERATURE DEVICES (RTDS)

#9	PROCESS CONNECTION SIZE & TYPE [3]		
L	1/8" NPT	O	3/4" NPT
M	1/4" NPT	X	Other, specify
A	3/8" NPT	Z	N/A
P	1/2" NPT (Standard)		

**Note:** Threaded bushing may be used for sizes larger than 1/2"

#10	LEAD WIRE TYPE & LENGTH IN INCHES [see section 7]		
1"	Fiberglass braid	X"	Other, specify
3"	Teflon (Standard)	Z"	N/A
4"	High temperature fiberglass braid		
5"	Kapton (Standard for Cryogenic)		

**Note:** All wire in tubes > 1/8" OD will be 24 AWG. Smaller tubes will have a max. of 28 AWG. If no transition or armor is specified, wire may be fragile. JMS standard lead wire for RTDs is stranded plated copper.

#11	ARMOR OR HEAT SHRINK/JACKET [7-7]		
A	SS flex armor (Standard)	G	Heat shrink/sleeving
B	SS flex armor Teflon coated white	H	Jacket to match primary insulation
C	SS flex armor Teflon coated black	J	Aluminum Mylar shielded and jacketed to match primary insulation
D	1/8" ID SS flex armor	Z	N/A
F	SS overbraid	X	Other, specify

#12	WIRE CONFIGURATION [17, 18]		
T	2 Wire	<b>Note:</b> Use a double symbol for 2 separate multiconductor lead wires, if dual elements. For example, TT.	
Y	3 Wire		
W	4 Wire		

#13	TYPE OF TRANSITION [14]		
H	Heat shrink	<b>Note:</b> For high humidity/moisture environments (≤ 500°F), put a 2 after your selection. For example, R2.	
S	Size on size		
T	3/8" OD	<b>Note:</b> For high temperatures at the transition area (500°F to 1200°F), put a 3 after your selection. For example, T3.	
R	1/4" OD		
Q	Cuttable (Std construction only) [3-12]		
X	Other, specify		
Z	No transition		

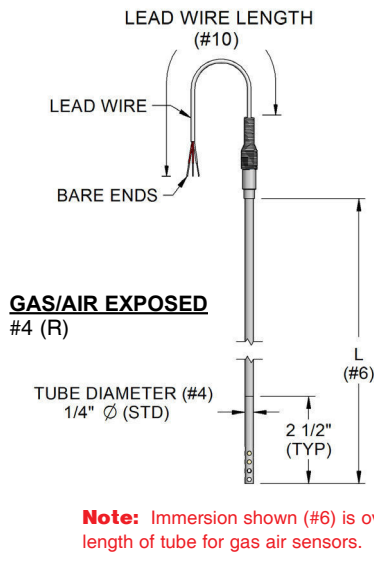

#14	COLD END TERMINATION [Additional options see Pg 1-7] Choose all that apply			
Connectors		Heads [6-1] Visit <a href="http://www.JMS-SE.com/headspecs">www.JMS-SE.com/headspecs</a>		
B	Miniature plug	Exp. Proof	I	Aluminum, NEMA 4X, FM, CSA, IP68 (6IA)
C	Standard plug		J	316 SS, NEMA 4X, FM, CSA, IP68 (6ISS)
F	High temp plug (< 800°F)	Gen. Purpose	P	Aluminum, NEMA 4X, FM, CSA, ATEX, IECEX, IP68 (6IAIEC)
WM	Microphone style plug		U	316 SS, NEMA 4X, FM, ATEX, IECEX, IP68 (6ISSATEX)
D	Miniature jack		L	Aluminum w/ hinged cover (6L)
E	Standard jack		M	Aluminum w/ screw cover & chain (6M)
G	High temp jack (< 800°F)		N	Cast Iron w/ screw cover (6N)
WF	Microphone style jack		Q	Black plastic (6Q)
V	Water resistant plug		R	Aluminum high dome w/ hinged cover (6R)
Y	M12 Water resistant plug		SS	316 SS w/ screw cover & chain (6SS)

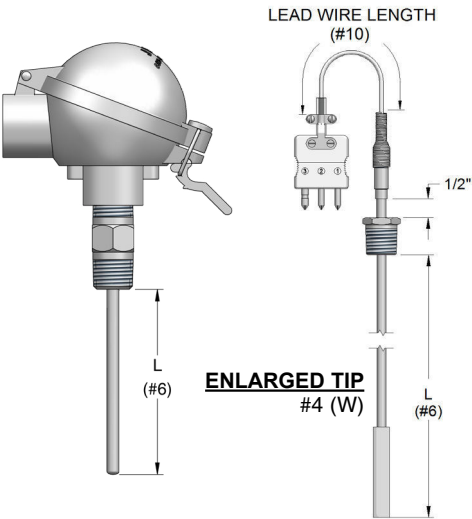

Transmitters		Transmitter & Housing [See Pg. 8-2]	
8H	Isolated transmitter	8PS	Indicating with SS housing
8N	Non-isolated transmitter	8PA	Indicating with aluminum housing
8I	Hart Protocol	Other	
8E	Intrinsically safe		
8D	HART / Intrinsically safe	A	Bare ends
8M	Integral transmitter (see page 3-5)	X	Other, specify

**Note:** Add span range after transmitter selection. Example: 8H(0-200C).

#15	OPTIONS (Use only if applicable)		
1	Stainless steel tag	6C*	Premium calibration report.
2	Plastic tag		Callendar-Van Dusen coefficients will be provided for all
3	Paper tag		
4	Laser etch on probe		
5	Calibrate at specified point(s)		
	Corrections data provided for each point.		
6*	Premium calibration report. Corrections data will be provided for all	7	CE marking [page XV]
		8	Guide 17025 calibration
		M	MTR (Sheath, tubing, tip)
		T	Calibration tag

**\*Must specify increments & range (Example: 0 to 300°F, 10° increments)**

### COMPLETE PART NUMBER EXAMPLES

-with nipple-union-spring-loaded fitting extension assembly:  
**3ESBNK12"BS[UN6H]PZZYZL1**  
 -without extension assembly:  
**3ESBNK12"BSPZZYZL1**

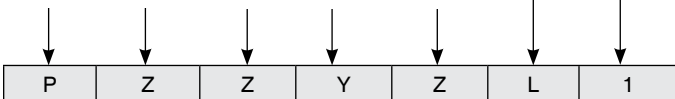

# THREADED, SOCKET WELD, & WELD-IN THERMOWELLS

**\*NEW\*** FREE Wake Frequency Calculations to ASME PTC 19.3 TW, **SwiftyCalc!**  
 Visit [JMS-SE.com](http://JMS-SE.com) to sign up today! [www.JMS-SE.com/SwiftyCalc](http://www.JMS-SE.com/SwiftyCalc)

#1	DESCRIPTION [See pages 5-20 through 5-24 for detailed information on dimensions, velocity ratings, and pressure ratings]							
5	Thermowells - Add a W here for a brass plug and stainless steel chain attached to well. (Example: 5W)							
	#2	SIZE	THREADED WELL External thread	SOCKET WELL Pipe size	Actual external Ø	WELD IN Actual external Ø	BUILT-UP Pipe size	
	1	1/2"	1/2" NPT	N/A	N/A	N/A	1/4" Sch 40 pipe	
	2	3/4"	3/4" NPT (Standard)	3/4" pipe	1.050"Ø (Standard)	N/A	1/2" Sch 40 pipe	
	3	1"	1" NPT	1" pipe	1.315"Ø	1.00"Ø	1/2" Sch 40 pipe	
	4	1-1/2"	1-1/2" NPT	1-1/2" pipe	1.900"Ø	1.50"Ø (Standard)	1/2" Sch 40 pipe	
	5	1-1/4"	1-1/4" NPT	1-1/4" pipe	1.660"Ø	1.25"Ø	1/2" Sch 40 pipe	
	X	Other, specify						
	#3	SHANK STYLE [15]					<b>Note:</b> Standard shank geometry fits 3000# rated socket/threadolet fittings. Use X to specify alternate geometry if needed.	
	A	Step (Standard)						
	S	Straight						
	T	Tapered						
	B*	Built-up (see page 5-2)						
	X	Other, specify					*Recommended if overall length of thermowell is 40" or greater	
	#4	PROCESS ENGAGEMENT						
	T	Threaded well design			W*	Weld In design		
	S	Socket weld well design			X	Other, specify		
		*Tapered shank standard Not available as Built-up						
	#5	BORE SIZE & SENSOR CONNECTION						
	2	.260" ID used for .250" OD sensors (Standard)						
	3	.385" ID used for .375" OD sensors (Straight or tapered shank style only)						
	X	Other, specify						
		<b>Note:</b> Add a N suffix for FNPT. (Example: 2N = .260" ID with 1/2" FNPT sensor connection)						
	#6	U (INSERTION) DEPTH [15]			STANDARD T DIMENSION	S/L SENSOR LENGTH		
	B	2-1/2"	*If overall length of thermowell is 40" or greater, JMS recommends the use of our "Built-up" shank style (option # 3) (see illustration on page 5-2)		2"	NO LAG	WITH LAG	
	C	4-1/2"			3"	4"	6"	
	D	6"			3"	6"	9"	
	E	7-1/2"			3"	7-1/2"	10-1/2"	
	F	10-1/2"			3"	9"	12"	
	G	13-1/2"			3"	12"	15"	
	H	16-1/2"			3"	15"	18"	
	I	22-1/2"			3"	18"	21"	
	U_*	Other, specify			3"	24"	27"	
		<b>Note:</b> Use U_ selection in place of X in legacy part numbers. (example: legacy part # 52AT2XTK1 X=5", is equivalent to 52AT2U5TK1)						
	#7	T (LAG) EXTENSION [15]						
	T	Standard lag (For lengths see chart in option #6)						
	Z	N/A (No lag)						
	T_ "	Other, specify						
		<b>Note:</b> Use T_ selection in place of X in legacy part numbers. (example: legacy part # 52AT2CXK1 X=4", is equivalent to 52AT2CT4K1)						
	#8	WELL MATERIAL [31-34]						
	A	Alloy 800H/HT		M	Inconel 600			
	B	F5		N	Monel A400			
	C	F9		Q	Hastelloy C-276			
	D	F91 Type 2		S	Titanium Grade 2			
	E	F22 Class 3		X*	Other, specify			
	F	F11 Class 2						
	G	Carbon steel A105			*For more options, like special jackets and coatings or unique material requirements, consult your sales representative directly.			
	H	304 stainless steel						
	I	Low Carbon 304 stainless steel						
	J	310 stainless steel						
	K	316 stainless steel (Standard)						
	L	Low Carbon 316 stainless steel						
	#9	OPTIONS						
	1	Stamped on well (Standard)						
	X*	Other, specify						
	M	MTR						
	W	Premium SwiftyCalc ASME 19.3TW calculation						
	N	NACE MRO175 Certification						
		<b>Note:</b> You must always specify information required on tag.						

**Note:** See illustrations below and on page 5-2 for specifications.

**Note:** Standard sensor connections are 1/2" FNPSM (female straight) to match 1/2" MNPT (male tapered) per ASME B40.200-2008 (B40.9) 1/4" female thread required for 1" weld in thermowell.

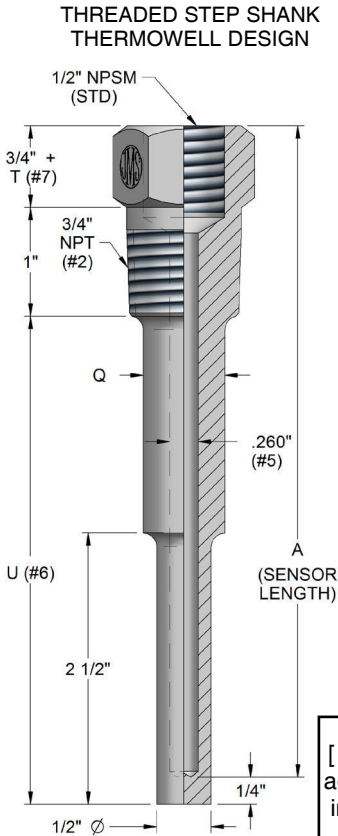

**Matching sensor lengths:**

- All Spring-loaded designs and all Compression designs with a nipple/union extension  
 $A = U \text{ length}(\#6) + 1 \frac{1}{2}'' + T \text{ length}(\#7)$
- All Welded designs  
 $A = U \text{ length}(\#6) + 3/4'' + T \text{ length}(\#7)$
- All Compression designs without a nipple/union extension  
 $A = U \text{ length}(\#6) + 3 \frac{3}{4}'' + T \text{ length}(\#7)$

[ ] Brackets indicate page numbers where additional helpful information can be found in technical catalog. Now available online at [www.JMS-SE.com/TechnicalCatalog](http://www.JMS-SE.com/TechnicalCatalog)

5 1 A T 2 B T A 1

# THREADED, SOCKET WELD & WELD-IN THERMOWELLS

**\*NEW\*** FREE Wake Frequency Calculations to ASME PTC 19.3 TW, **SwiftCalc!**

Visit [JMS-SE.com](http://JMS-SE.com) to sign up today! [www.JMS-SE.com/SwiftyCalc](http://www.JMS-SE.com/SwiftyCalc)

(JMS Southeast, Inc. participated in the ASME 19.3 TW committee performing the first major revision since 1974 to the only US thermowell strength standard. The new ASME PTC 19.3 TW standard addresses wake frequency calculations.)

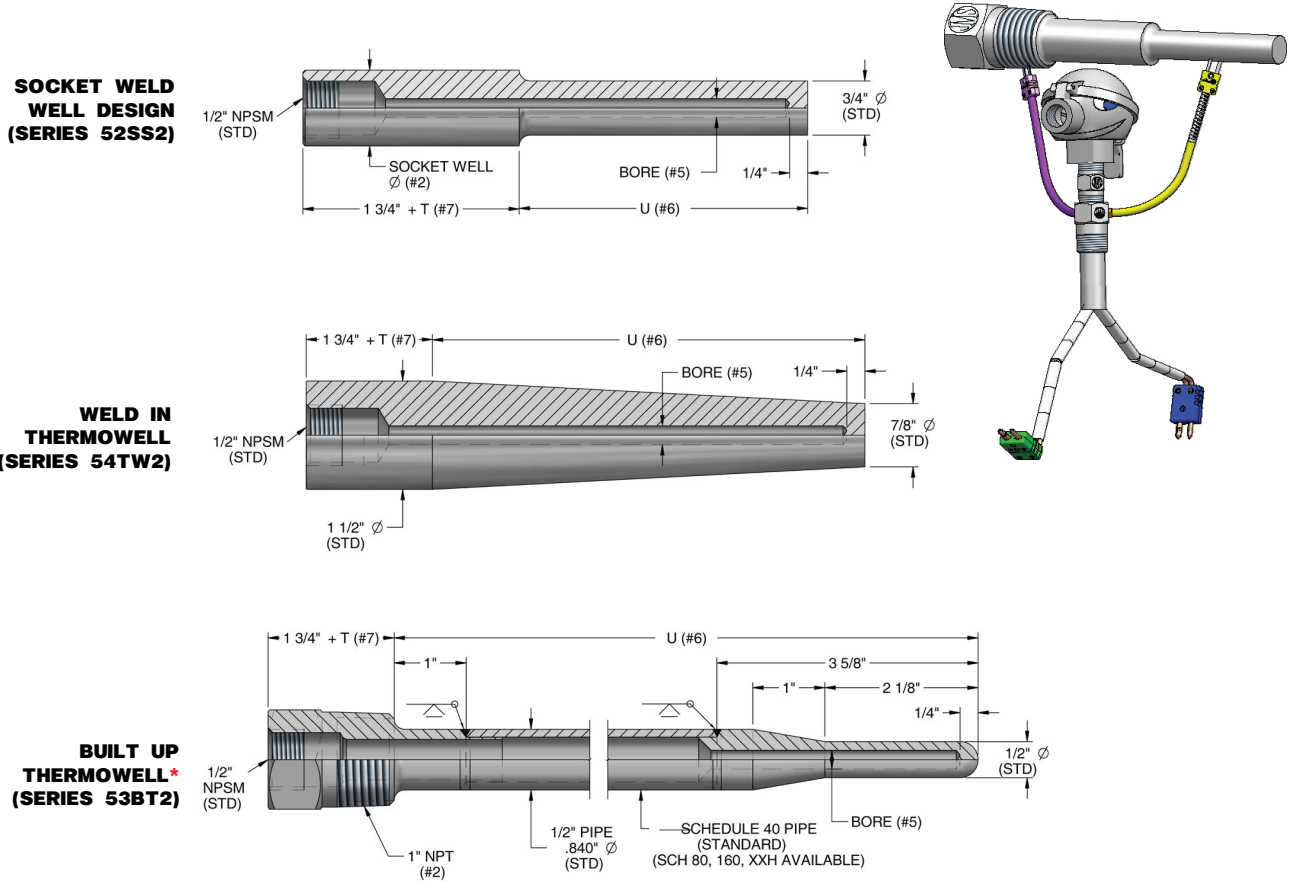

## LIMITED SPACE THERMOWELLS

#1	DESCRIPTION
5L	Limited space thermowells - Add a W here for a Brass plug and stainless steel chain attached to well (Example: 5LW)
#2	WELL MATERIAL & PROCESS CONNECTION SIZE
H	304 stainless steel
K	316 stainless steel
M	Inconel 600
X	Other, specify
#3	OPTIONS
1	Stamped on well (Standard)
X*	Other
M	MTR

Standard process connection is 1" NPT. Add a 1 prefix for a 1/2" NPT or a 2 prefix for a 3/4" NPT (Example: 1H = 304 SS with 1/2" NPT process connection) Add an N as a suffix for a NPT Instrument Connection.

**Note:** Immersion length of a spring-loaded sensor to fit this well is 2-1/2".

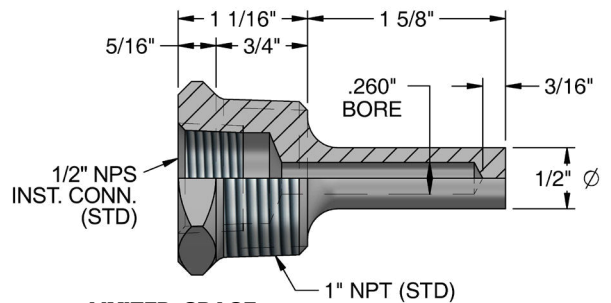

**LIMITED SPACE THERMOWELL**

5L	M	1
----	---	---