

THREADED, SOCKET WELD, & WELD-IN THERMOWELLS

NEW **FREE** Wake Frequency Calculations to ASME PTC 19.3 TW, **SwiftyCalc!**
 Visit JMS-SE.com to sign up today! www.JMS-SE.com/SwiftyCalc

#1	DESCRIPTION [See pages 5-20 through 5-24 for detailed information on dimensions, velocity ratings, and pressure ratings]							
5	Thermowells - Add a W here for a brass plug and stainless steel chain attached to well. (Example: 5W)							
	#2	SIZE	THREADED WELL External thread	SOCKET WELL Pipe size	Actual external Ø	WELD IN Actual external Ø	BUILT-UP Pipe size	
	1	1/2"	1/2" NPT	N/A	N/A	N/A	1/4" Sch 40 pipe	
	2	3/4"	3/4" NPT (Standard)	3/4" pipe	1.050"Ø (Standard)	N/A	1/2" Sch 40 pipe	
	3	1"	1" NPT	1" pipe	1.315"Ø	1.00"Ø	1/2" Sch 40 pipe	
	4	1-1/2"	1-1/2" NPT	1-1/2" pipe	1.900"Ø	1.50"Ø (Standard)	1/2" Sch 40 pipe	
	5	1-1/4"	1-1/4" NPT	1-1/4" pipe	1.660"Ø	1.25"Ø	1/2" Sch 40 pipe	
	X	Other, specify						
	#3	SHANK STYLE [15]					Note: Standard shank geometry fits 3000# rated socket/threadolet fittings. Use X to specify alternate geometry if needed.	
	A	Step (Standard)						
	S	Straight						
	T	Tapered						
	B*	Built-up (see page 5-2)						
	X	Other, specify					*Recommended if overall length of thermowell is 40" or greater	
	#4	PROCESS ENGAGEMENT						
	T	Threaded well design			W*	Weld In design		
	S	Socket weld well design			X	Other, specify		
		*Tapered shank standard Not available as Built-up						
	#5	BORE SIZE & SENSOR CONNECTION						
	2	.260" ID used for .250" OD sensors (Standard)						
	3	.385" ID used for .375" OD sensors (Straight or tapered shank style only)						
	X	Other, specify						
		Note: Add a N suffix for FNPT. (Example: 2N = .260" ID with 1/2" FNPT sensor connection)						
	#6	U (INSERTION) DEPTH [15]			STANDARD T DIMENSION	S/L SENSOR LENGTH		
	B	2-1/2"	*If overall length of thermowell is 40" or greater, JMS recommends the use of our "Built-up" shank style (option # 3) (see illustration on page 5-2)		2"	NO LAG	WITH LAG	
	C	4-1/2"			2"	4"	6"	
	D	6"			3"	6"	9"	
	E	7-1/2"			3"	7-1/2"	10-1/2"	
	F	10-1/2"			3"	9"	12"	
	G	13-1/2"			3"	12"	15"	
	H	16-1/2"			3"	15"	18"	
	I	22-1/2"			3"	18"	21"	
	U_	Other, specify			3"	24"	27"	
		Note: Use U_ selection in place of X in legacy part numbers. (example: legacy part # 52AT2XTK1 X=5", is equivalent to 52AT2U5TK1)						
	#7	T (LAG) EXTENSION [15]						
	T	Standard lag (For lengths see chart in option #6)						
	Z	N/A (No lag)						
	T_	Other, specify						
		Note: Use T_ selection in place of X in legacy part numbers. (example: legacy part # 52AT2CXK1 X=4", is equivalent to 52AT2CT4K1)						
	#8	WELL MATERIAL [31-34]						
	A	Alloy 800H/HT		M	Inconel 600			
	B	F5		N	Monel A400			
	C	F9		Q	Hastelloy C-276			
	D	F91 Type 2		S	Titanium Grade 2			
	E	F22 Class 3		X*	Other, specify			
	F	F11 Class 2						
	G	Carbon steel A105			*For more options, like special jackets and coatings or unique material requirements, consult your sales representative directly.			
	H	304 stainless steel						
	I	Low Carbon 304 stainless steel						
	J	310 stainless steel						
	K	316 stainless steel (Standard)						
	L	Low Carbon 316 stainless steel						
	#9	OPTIONS						
	1	Stamped on well (Standard)						
	X*	Other, specify						
	M	MTR						
	W	Premium SwiftyCalc ASME 19.3TW calculation						
	N	NACE MRO175 Certification						
		Note: You must always specify information required on tag.						

Note: See illustrations below and on page 5-2 for specifications.

Note: Standard sensor connections are 1/2" FNPSM (female straight) to match 1/2" MNPT (male tapered) per ASME B40.200-2008 (B40.9) 1/4" female thread required for 1" weld in thermowell.

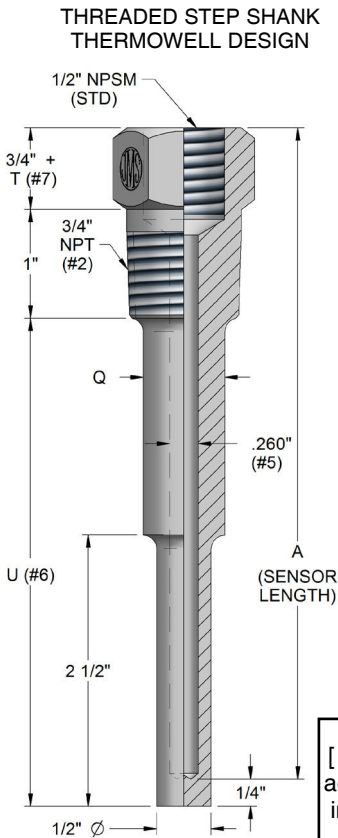

Matching sensor lengths:

- All Spring-loaded designs and all Compression designs with a nipple/union extension
 $A = U \text{ length}(\#6) + 1 \frac{1}{2}'' + T \text{ length}(\#7)$
- All Welded designs
 $A = U \text{ length}(\#6) + 3/4'' + T \text{ length}(\#7)$
- All Compression designs without a nipple/union extension
 $A = U \text{ length}(\#6) + 3 \frac{3}{4}'' + T \text{ length}(\#7)$

[] Brackets indicate page numbers where additional helpful information can be found in technical catalog. Now available online at www.JMS-SE.com/TechnicalCatalog

5	1	A	T	2	B	T	A	1
---	---	---	---	---	---	---	---	---

THREADED, SOCKET WELD & WELD-IN THERMOWELLS

NEW FREE Wake Frequency Calculations to ASME PTC 19.3 TW, **SwiftCalc!**

Visit JMS-SE.com to sign up today! www.JMS-SE.com/SwiftyCalc

(JMS Southeast, Inc. participated in the ASME 19.3 TW committee performing the first major revision since 1974 to the only US thermowell strength standard. The new ASME PTC 19.3 TW standard addresses wake frequency calculations.)

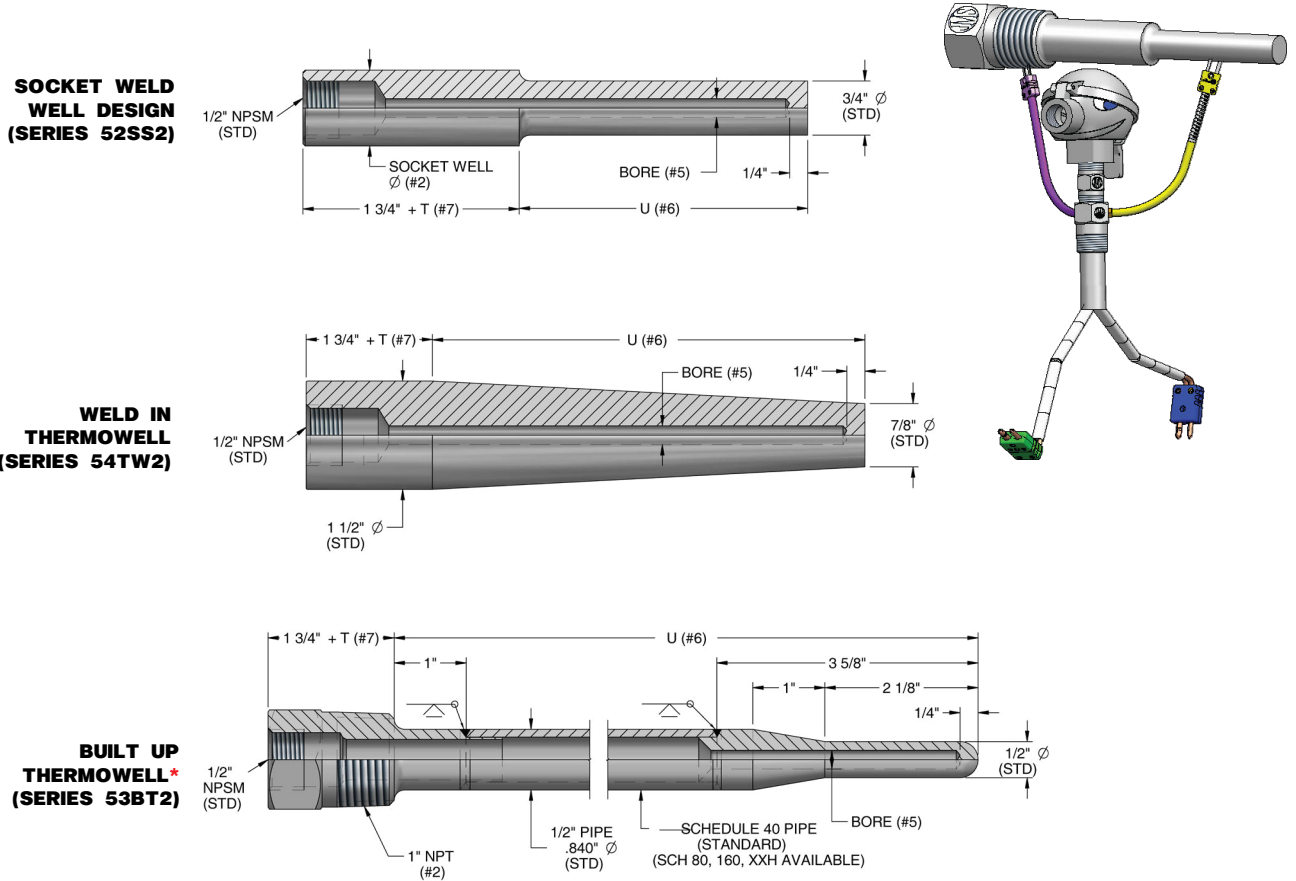

LIMITED SPACE THERMOWELLS

#1	DESCRIPTION
5L	Limited space thermowells - Add a W here for a Brass plug and stainless steel chain attached to well (Example: 5LW)
#2	WELL MATERIAL & PROCESS CONNECTION SIZE
H	304 stainless steel
K	316 stainless steel
M	Inconel 600
X	Other, specify
#3	OPTIONS
1	Stamped on well (Standard)
X*	Other
M	MTR

Standard process connection is 1" NPT. Add a 1 prefix for a 1/2" NPT or a 2 prefix for a 3/4" NPT (Example: 1H = 304 SS with 1/2" NPT process connection) Add an N as a suffix for a NPT Instrument Connection.

Note: Immersion length of a spring-loaded sensor to fit this well is 2-1/2".

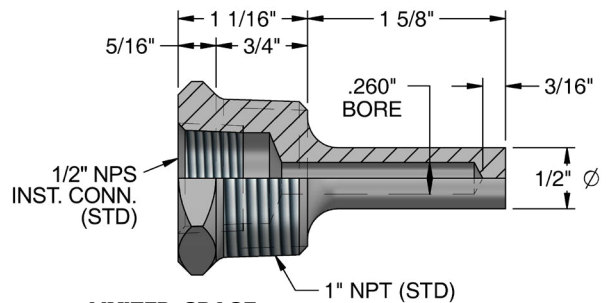

LIMITED SPACE THERMOWELL

5L	M	1
----	---	---