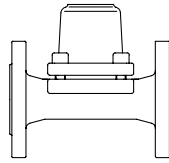


Bimetallic steam trap

Bimetallic steam trap

PN16

- with flanges (Fig. 600....1)
- union with butt weld ends (Fig. 600....5)



Grey cast iron
Fig. 600 Page 2

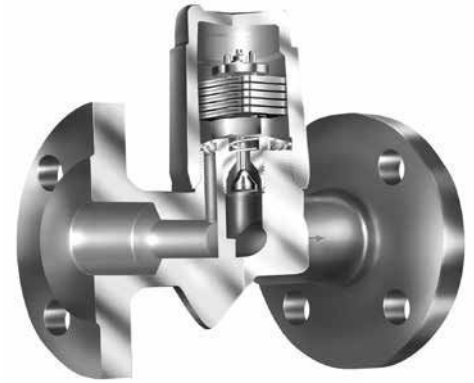
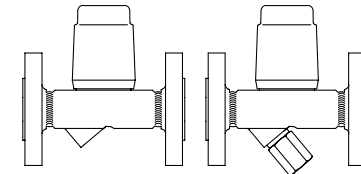


Fig. 600....1 (PN40)

Bimetallic steam trap

PN40

- with flanges (Fig. 600/601....1)
- with screwed sockets (Fig. 600/601....2)
- with socket weld ends (Fig. 600/601....3)
- with butt weld ends (Fig. 600/601....4)



Forged steel DN15-25 Page 4
High temperature steel DN40-50 Page 6
Stainless steel DN40-50 Page 6
Fig. 600/601 (Y)

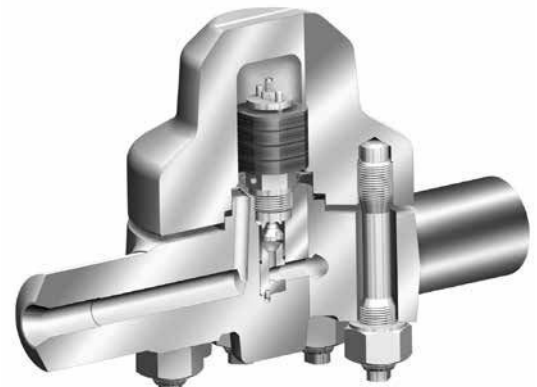
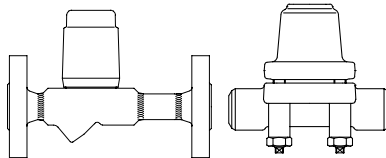


Fig. 600....4 (PN630)

Bimetallic steam trap

PN63 / PN100

- with flanges (Fig. 600....1)
- with socket weld ends (Fig. 600....3)
- with butt weld ends (Fig. 600....4)

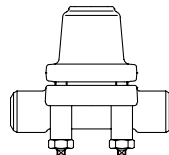


High temperature steel DN15-25 Page 8
DN40-50 Page 12
Fig. 600

High pressure bimetallic steam trap

PN160 / PN250

- with flanges (Fig. 600....1)
- with socket weld ends (Fig. 600....3)
- with butt weld ends (Fig. 600....4)

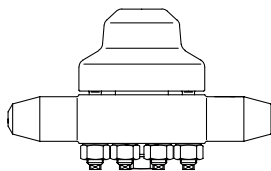


High temperature steel
Fig. 600 Page 14

High pressure bimetallic steam trap

PN320 / PN400 / PN630

- with flanges (up to PN400) (Fig. 600....1)
- with socket weld ends (Fig. 600....3)
- with butt weld ends (Fig. 600....4)



High temperature steel
Fig. 600 Page 16

Features:

- For discharging of slight to highly sub-cooled condensate
- Automatic air-venting during start up and operation of the plant
- Robust and resistant to water-hammer
- Integrated Check valve
- Design with internal strainer - Fig. 600
Design with outside strainer (Y) - Fig. 601 (Y)
- Optimized design for quick installation (PN40, PN63 with R46, DN15-25)
- Gasket-free sealing of the screwed cap (PN40 and PN63 with Cap, DN15-25)
- Installation in any position (except cover/screwed cap downwards)
- Subcooling of condensate is continuously adjustable (observe the operation instructions)
- The controller maybe changed without disturbing the pipe work

W. T. Maye, Inc.
1-877-705-9864
info@wtmi-usa.com
www.wtmi-usa.com

Bimetallic steam trap (Grey cast iron)

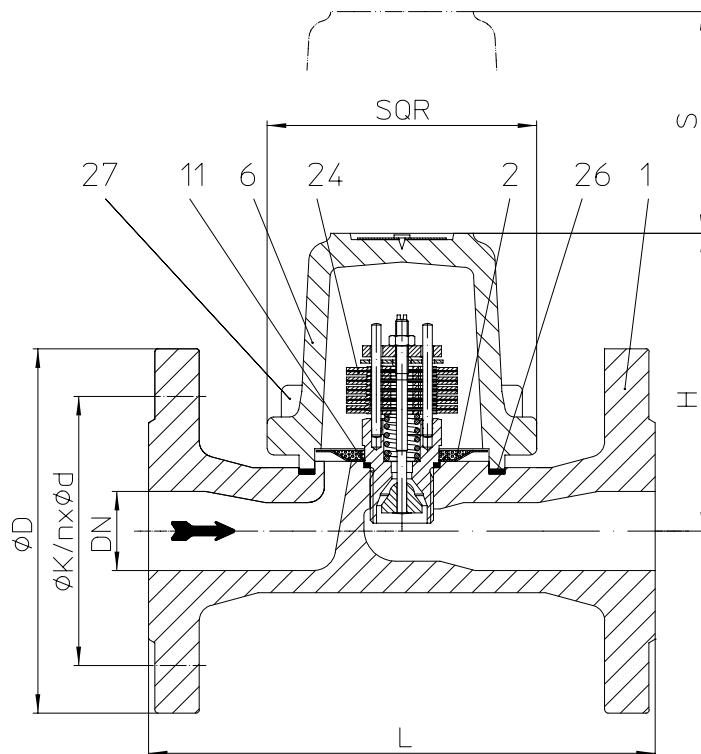


Fig. 600...1 with inside strainer

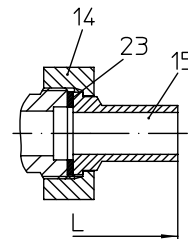


Fig. 600...5
union with butt weld ends

W. T. Maye, Inc.
1-877-705-9864
info@wtmi-usa.com
www.wtmi-usa.com

Figure	Nominal pressure	Material	Nominal diameter / NPS	Operating pressure PS	Inlet temperature TS	allowable differential pressure ΔPMX	for controller
12.600	PN16	EN-JL1040	DN15-50 / 1/2" - 2"	12,8 barg	200 °C	13 bar	R13
				9,6 barg	300 °C		

For ANSI versions refer to data sheet CONA®B-ANSI

Types of connection

Other types of connection on request.

- Flanges1 _____ acc. to DIN EN 1092-2
- Union butt weld nipples5 _____ acc. to data sheet resp. customer request

Features

- Thermostatic steam trap with non-corrosive and robust water hammer proof bimetallic controller
- Automatic air-venting during start up and operation of the plant
- Check valve
- With inside strainer
- Installation in any position, except cover downwards
- Subcooling of condensate is continuously adjustable (observe the operation instructions)

Controller

(chooseable for operating range)

- Controller R13 _____ up to inlet pressure: 13 bar

Types of connection	Flanges		Union butt weld nipples	
DN	25	50	15	20
NPS	1"	2"	1/2"	3/4"

Face-to-face acc. to data sheet resp. customer request					
L	(mm)	160	230	190	190

Dimensions		Standard-flange dimensions refer to page 23 / Larger nominal diameters refer to page 4.			
H	(mm)	100	124	100	100
S	(mm)	70	90	70	70
SQR	(mm)	85	105	85	85

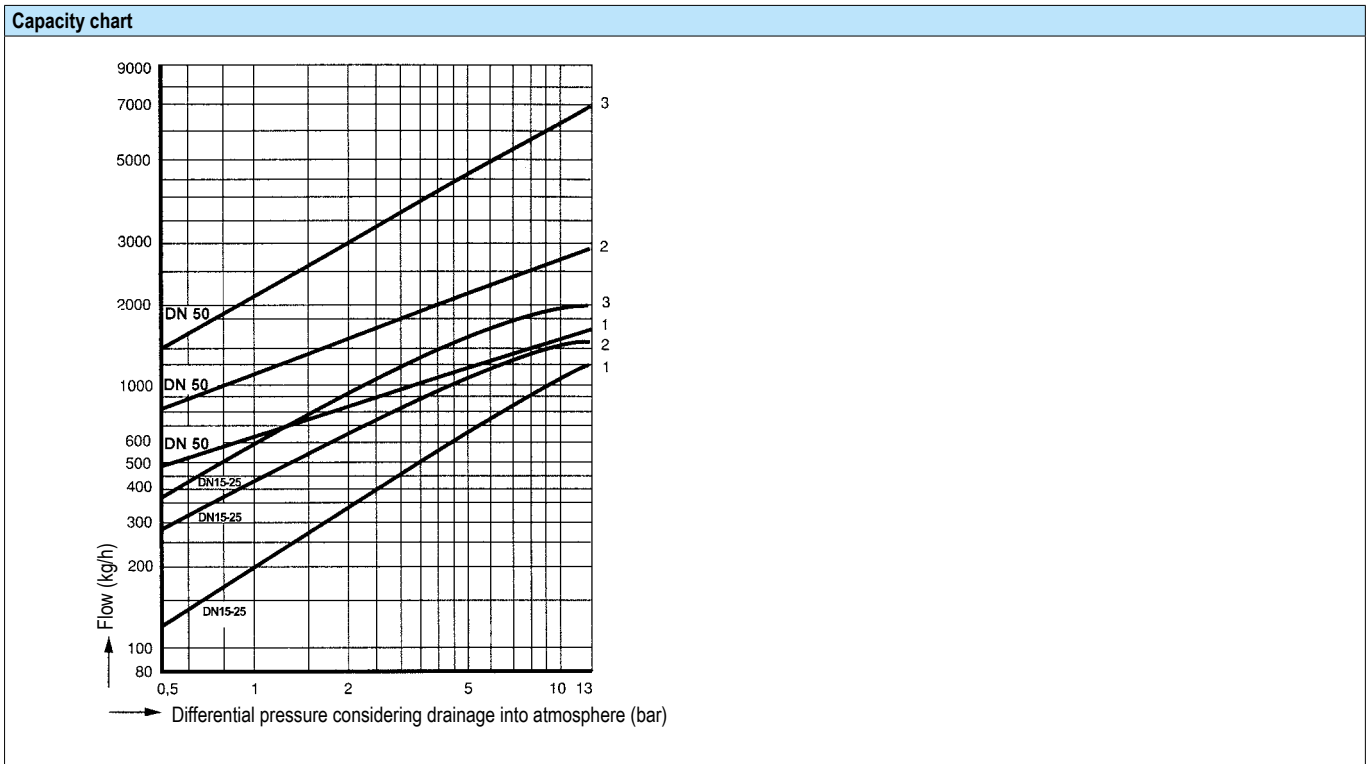
Weights					
Fig. 600	(approx.) (kg)	4,6	10	2,6	2,3

Parts			
Pos.	Sp.p.	Description	Fig. 12.600
1		Body	EN-GJL-250, EN-JL1040
2	x	Strainer	X5CrNi18-10, 1.4301
6		Cover	EN-GJL-250, EN-JL1040
11	x	Sealing ring	CU
14		Union nut	11SMn30+C, 1.0715+C
15		Welding end	C15, 1.0401
23	x	Sealing ring	Novapress MULTI
24	x	Controller, cpl.	TB 102 / 85 (corrosion resistant bimetal)
26	x	Gasket	Graphite (CrNi laminated with graphite)
27		Cheese head screw	A2-70
L Spare parts			

Information / restriction of technical rules need to be observed!

Resistance and fitness must be verified (contact manufacturer for information, refer to Product overview and Resistance list).

Operating and installation instructions can be downloaded at www.ari-armaturen.com.



The capacity chart shows the maximum capacity at factory setting.
(Other factory-settings for the sub-cooling on request.)

Curve 1: Maximum flow of hot condensate at approx. 10 K below saturation temperature.

Curve 2: Maximum flow of sub-cooled condensate at approx. 30 K below saturation temperature (with back-up of condensate).

Curve 3: Maximum flow at cold condensate at about 20°C (during start-up of a cold installation).

W. T. Maye, Inc.
1-877-705-9864
info@wtmi-usa.com
www.wtmi-usa.com

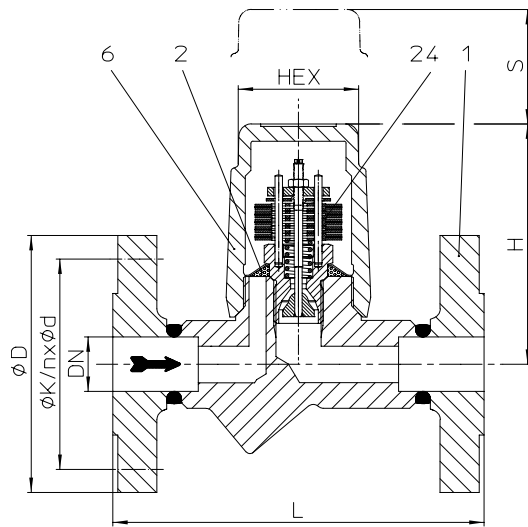
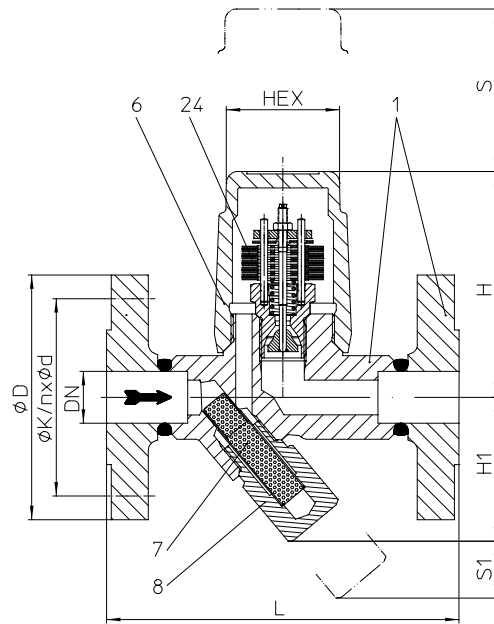
Bimetallic steam trap (Forged steel, High temperature steel, Stainless steel)


Fig. 600....1 with inside strainer



601....1 with outside strainer (Y)

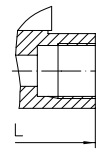
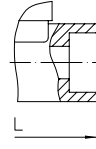
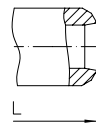

 Fig. 600/601....2
 with screwed sockets

 Fig. 600/601....3
 with socket weld ends

 Fig. 600/601....4
 with butt weld ends

Figure	Nominal pressure	Material	Nominal diameter / NPS	Operating pressure PS	Inlet temperature TS	allowable differential pressure ΔPMX	for controller
45.600 45.601 (Y)	PN40	1.0460	DN15-25 / 1/2" - 1"	32 barg	250 °C	32 bar 22 bar 13 bar	R32 R22 R13
				22 barg	385 °C		
				14,5 barg	450 °C		
85.600 85.601 (Y)	PN40	16Mo3	DN15-25 / 1/2" - 1"	35 barg	300 °C		
				32 barg	335 °C		
				28 barg	450 °C		
55.600 55.601 (Y)	PN40	1.4541	DN15-25 / 1/2" - 1"	32 barg	350 °C		
				22 barg	400 °C		

For ANSI versions refer to data sheet CONA®B-ANSI

Types of connection Other types of connection on request.

- Flanges1 _____ acc. to DIN EN 1092-1
- Screwed sockets2 _____ Rp thread acc. to DIN EN 10226-1 or NPT thread acc. to ANSI B1.20.1
- Socket weld ends3 _____ acc. to DIN EN 12760
- Butt weld ends4 _____ Weld preparation acc. to EN ISO 9692 identification No. 1.3 and 1.5
(Note restriction on operating pressure / inlet temperature depending to design!)

Features

- Thermostatic steam trap with non-corrosive and robust water hammer proof bimetallic controller
- Automatic air-venting during start up and operation of the plant
- Check valve
- With inside strainer - Fig. 600 / with outside strainer - Fig. 601 (Y)
- Installation in any position, except screw cap downwards
- Subcooling of condensate is continuously adjustable (observe the operation instructions)
- Maintenance simplified due to screwed cap without sealing

Controller (chooseable for operating range)

- Controller R13 _____ up to inlet pressure: 13 bar
- Controller R22 _____ up to inlet pressure: 22 bar
- Controller R32 _____ up to inlet pressure: 32 bar

Options (Design refer to page 5)

- Outside strainer with blow down valve (Pos. 46)
- Ball valve for blow down (pos. 56) with internal strainer (Observe operating and installation instructions!)

Types of connection	Flanges			Screw sockets Socket weld ends			Butt weld ends		
	DN	15	20	25	15	20	25	15	20
NPS	1/2"	3/4"	1"	1/2"	3/4"	1"	1/2"	3/4"	1"

Face-to-face acc. to data sheet resp. customer request										
L	(mm)	150	150	160	95	95	95	250	250	250

Dimensions										
Standard-flange dimensions refer to page 23 / Larger nominal diameters refer to page 6.										
H	(mm)	98	98	98	98	98	103	98	98	98
H1	(mm)	62	62	62	62	62	55	62	62	62
S	(mm)	70	70	70	70	70	70	70	70	70
S1	(mm)	30	30	30	30	30	30	30	30	30
HEX	(mm)	50	50	50	50	50	50	50	50	50

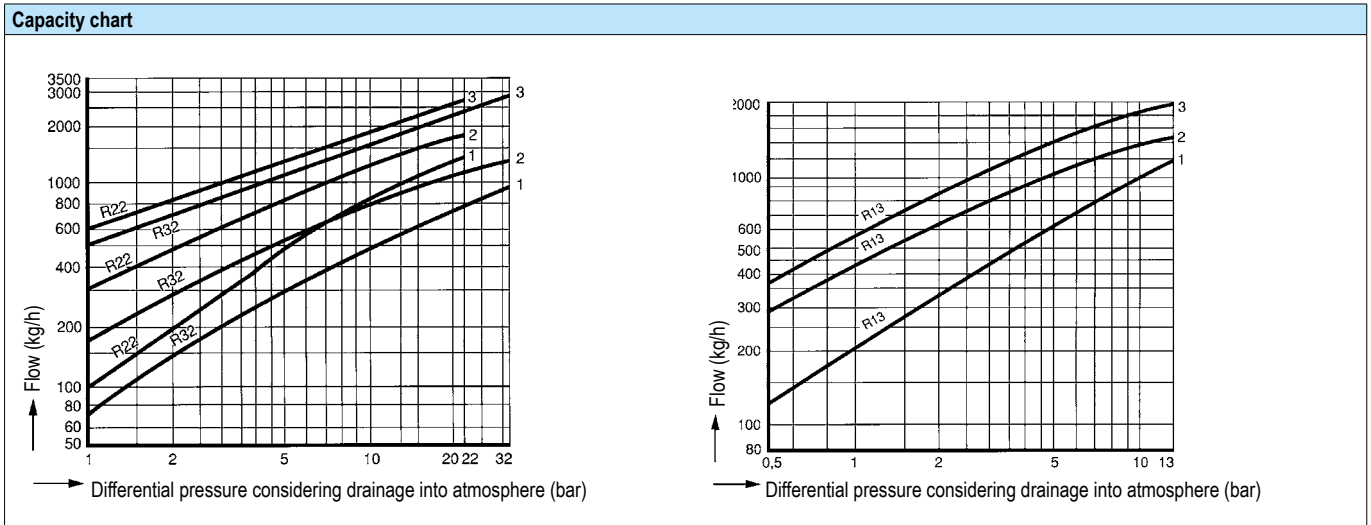
Weights											
Fig. 600 / 601	(approx.)	(kg)	3,2	3,7	4,2	1,7	1,6	2,1	2,2	2,3	2,4

Parts					
Pos.	Sp.p.	Description	Fig. 45.600 / 45.601	Fig. 85.600 / 85.601	Fig. 55.600 / 55.601
1		Body	P250 GH, 1.0460	16Mo3, 1.5415	X6CrNiTi18-10, 1.4541
2	x	Strainer	X5CrNi18-10, 1.4301		
6		Cap	P250 GH, 1.0460	16Mo3, 1.5415	X6CrNiTi18-10, 1.4541
7	x	Strainer	X5CrNi18-10, 1.4301		
8	x	Strainer plug	X6CrNiTi18-10, 1.4541		
24	x	Controller, cpl.	TB 102 / 85 (corrosion resistant bimetal)		
46	x	Blow down valve, cpl.	X6CrNiTi18-10, 1.4541		
56	x	Ball valve for blow down (G 3/8")	GX5CrNiMo19-11-2, 1.4408		
L Spare parts					

Information / restriction of technical rules need to be observed!

Resistance and fitness must be verified (contact manufacturer for information, refer to Product overview and Resistance list).

Operating and installation instructions can be downloaded at www.ari-armaturen.com.



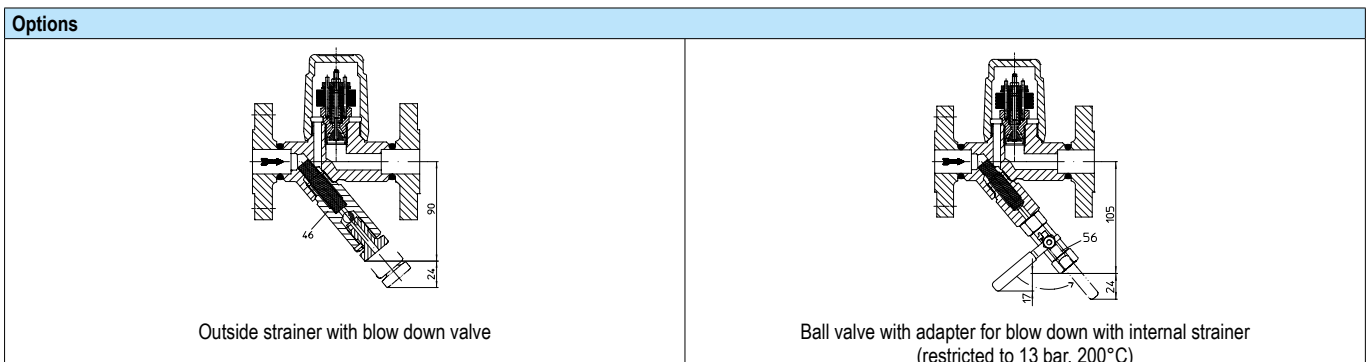
The capacity chart shows the maximum capacity at factory setting. (Other factory-settings for the sub-cooling on request.)

Curve 1: Maximum flow of hot condensate at approx. 10 K below saturation temperature.

Curve 2: Maximum flow of sub-cooled condensate at approx. 30 K below saturation temperature (with back-up of condensate).

Curve 3: Maximum flow at cold condensate at about 20°C (during start-up of a cold installation).

The condensate temperature determines the opening of the controller. Capacity is increased with the sub-cooling temperature of the condensate.



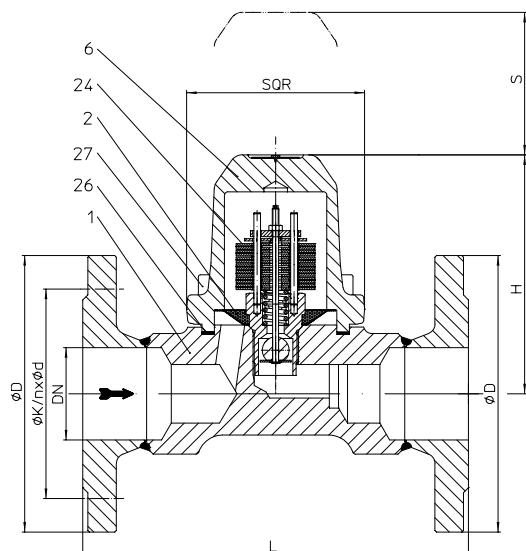
Bimetallic steam trap (Forged steel, High temperature steel, Stainless steel)


Fig. 600....1 with inside strainer

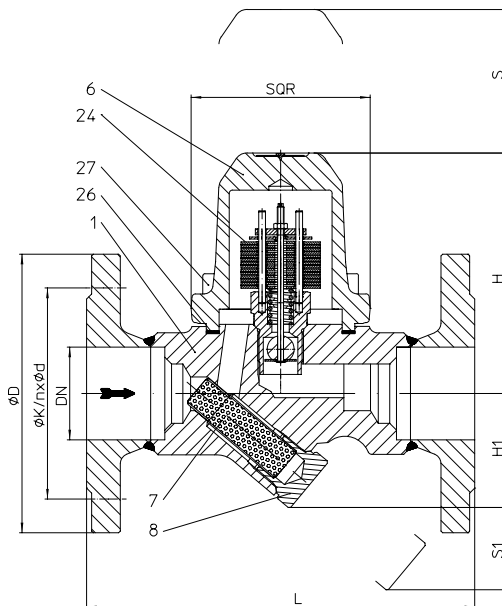


Fig. 601....1 with outside strainer (Y)

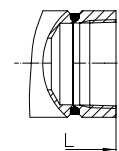
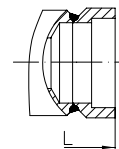
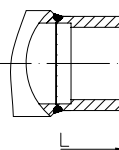

 Fig. 600/601....2
with screwed sockets

 Fig. 600/601....3
with socket weld ends

 Fig. 600/601....4
with butt weld ends

Figure	Nominal pressure	Material	Nominal diameter / NPS	Operating pressure PS	Inlet temperature TS	allowable differential pressure ΔPMX	for controller
45.600 45.601 (Y)	PN40	1.0460	DN40-50 / 1 1/2" - 2"	32 barg	250 °C	32 bar 22 bar 13 bar	R32 R22 R13
				22 barg	385 °C		
				14,5 barg	450 °C		
85.600 85.601 (Y)	PN40	16Mo3	DN40-50 / 1 1/2" - 2"	35 barg	300 °C		
				32 barg	335 °C		
				28 barg	450 °C		
55.600 55.601 (Y)	PN40	1.4541	DN40-50 / 1 1/2" - 2"	32 barg	350 °C		
				22 barg	400 °C		

For ANSI versions refer to data sheet CONA®B-ANSI

Types of connection	Other types of connection on request.
<ul style="list-style-type: none"> Flanges1 _____ acc. to DIN EN 1092-1 Screwed sockets2 _____ Rp thread acc. to DIN EN 10226-1 or NPT thread acc. to ANSI B1.20.1 Socket weld ends3 _____ acc. to DIN EN 12760 Butt weld ends4 _____ Weld preparation acc. to EN ISO 9692 identification No. 1.3 and 1.5 (Note restriction on operating pressure / inlet temperature depending to design!) 	
Features	
<ul style="list-style-type: none"> Thermostatic steam trap with non-corrosive and robust water hammer proof bimetallic controller Automatic air-venting during start up and operation of the plant Check valve With inside strainer - Fig. 600 / with outside strainer - Fig. 601 (Y) Installation in any position, except cover downwards Subcooling of condensate is continuously adjustable (observe the operation instructions) 	
Controller	(chooseable for operating range)
<ul style="list-style-type: none"> Controller R13 _____ up to inlet pressure: 13 bar Controller R22 _____ up to inlet pressure: 22 bar Controller R32 _____ up to inlet pressure: 32 bar 	
Options	(Design refer to page 5)
<ul style="list-style-type: none"> Outside strainer with blow down valve (Pos. 46) Ball valve for blow down (pos. 56) with internal strainer (Observe operating and installation instructions!) 	

Types of connection	Flanges		Screwed sockets Socket weld ends		Butt weld ends	
	40	50	40	50	40	50
DN	40	50	40	50	40	50
NPS	1 1/2"	2"	1 1/2"	2"	1 1/2"	2"

Face-to-face acc. to data sheet resp. customer request							
L	(mm)	230	230	130 / 160 ¹⁾	210	250	250

¹⁾ Construction with screwed sockets

Dimensions		Standard-flange dimensions refer to page 23					
H	(mm)	144	144	144	144	144	144
H1	(mm)	68	68	68	68	68	68
S	(mm)	90	90	90	90	90	90
S1	(mm)	50	50	50	50	50	50
SQR	(mm)	110	110	110	110	110	110

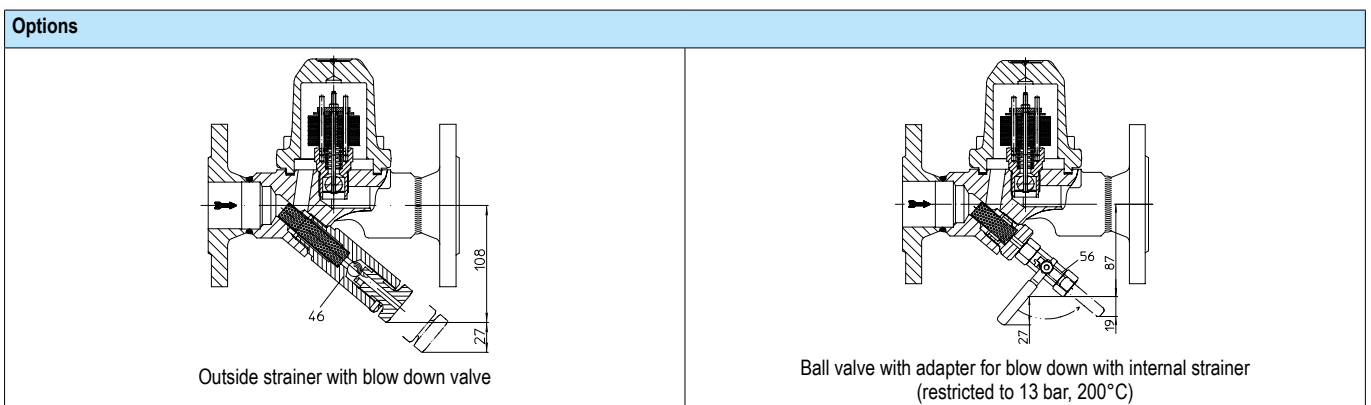
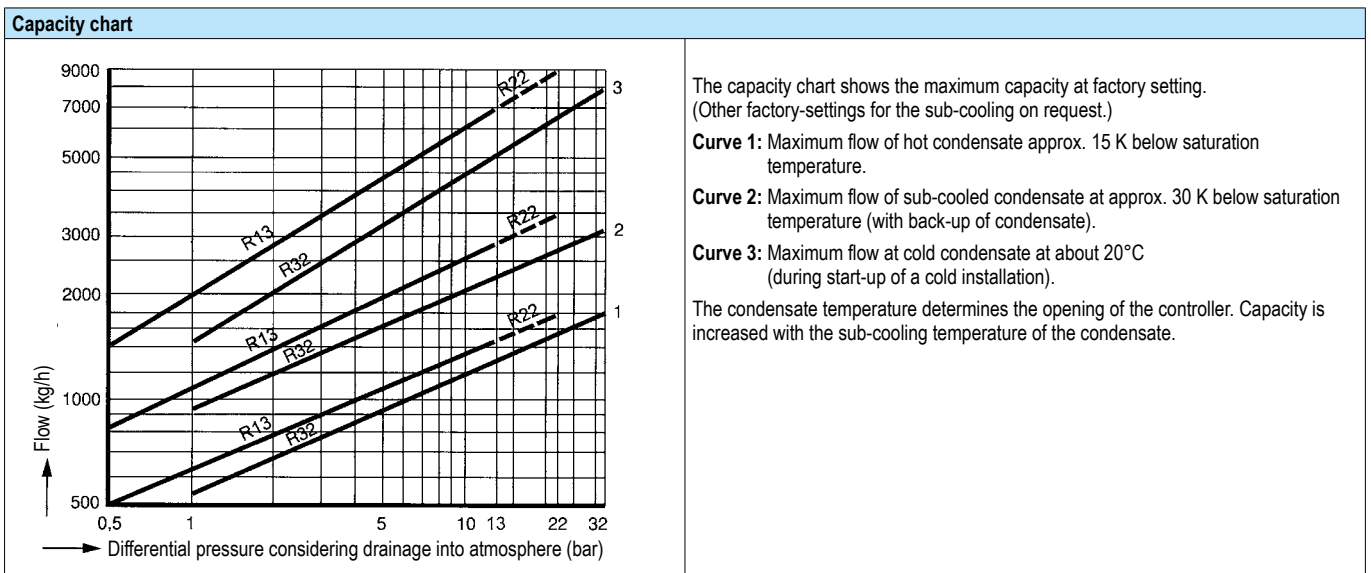
Weights								
Fig. 600 / 601	(approx.)	(kg)	11,3	12,1	8	8	8,9	9,8

Parts							
Pos.	Sp.p.	Description	Fig. 45.600 / 45.601	Fig. 85.600 / 85.601	Fig. 55.600 / 55.601		
1		Body	P250 GH, 1.0460	16Mo3, 1.5415	X6CrNiTi18-10, 1.4541		
2	x	Strainer	X5CrNi18-10, 1.4301				
6		Cover	P250 GH, 1.0460	16Mo3, 1.5415	X6CrNiTi18-10, 1.4541		
7	x	Strainer	X5CrNi18-10, 1.4301				
8	x	Strainer plug	X6CrNiTi18-10, 1.4541				
24	x	Controller, cpl.	TB 102 / 85 (corrosion resistant bimetal)				
26	x	Gasket	Graphite (CrNi laminated with graphite)				
27		Cheese head screw	21CrMoV 5-7, 1.7709				
46	x	Blow down valve, cpl.	X6CrNiTi18-10, 1.4541				
56	x	Ball valve for blow down (G 3/8")	GX5CrNiMo19-11-2, 1.4408				
L Spare parts							

Information / restriction of technical rules need to be observed!

Resistance and fitness must be verified (contact manufacturer for information, refer to Product overview and Resistance list).

Operating and installation instructions can be downloaded at www.ari-armaturen.com.



Bimetallic steam trap (High temperature steel)

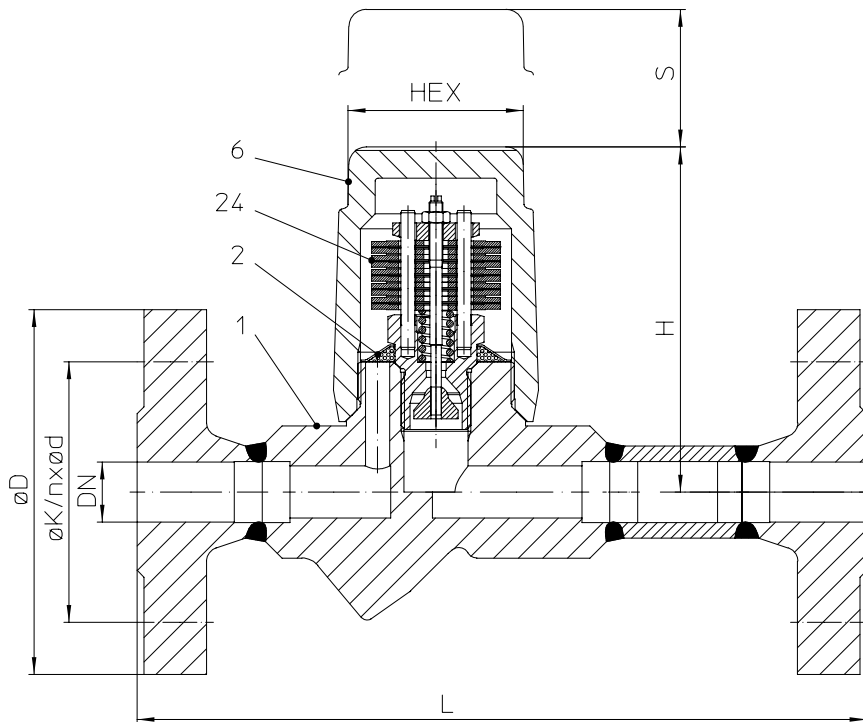


Fig. 600....1 with inside strainer

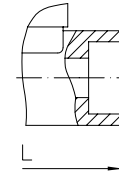


Fig. 600....3
with socket weld ends

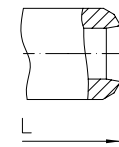


Fig. 600....4
with butt weld ends

W. T. Maye, Inc.
1-877-705-9864
info@wtmi-usa.com
www.wtmi-usa.com

Figure	Nominal pressure	Material	Nominal diameter / NPS	Operating pressure PS	Inlet temperature TS	allowable differential pressure ΔPMX	for controller
86.600	PN63	16Mo3	DN15-25 / 1/2" - 1"	46 barg	425 °C	46 bar	R46
				45 barg	450 °C		

For ANSI versions refer to data sheet CONA®B-ANSI

Types of connection	Other types of connection on request.
<ul style="list-style-type: none"> Flanges1 _____ acc. to DIN EN 1092-1 Socket weld ends3 _____ acc. to DIN EN 12760 Butt weld ends4 _____ Weld preparation acc. to EN ISO 9692 identification No. 1.3 and 1.5 (Note restriction on operating pressure / inlet temperature depending to design!) 	
Features	
<ul style="list-style-type: none"> Thermostatic steam trap with non-corrosive and robust water hammer proof bimetallic controller Automatic air-venting during start up and operation of the plant Check valve With inside strainer Installation in any position, except screw cap downwards Subcooling of condensate is continuously adjustable (observe the operation instructions) Maintenance simplified due to screwed cap without sealing 	
Controller	(chooseable for operating range)
<ul style="list-style-type: none"> Controller R46 _____ up to inlet pressure: 46 bar 	

Types of connection	Flanges			Socket weld ends			Butt weld ends ¹⁾		
	15	20	25	15	20	25	15	20	25
DN	15	20	25	15	20	25	15	20	25
NPS	1/2"	3/4"	1"	1/2"	3/4"	1"	1/2"	3/4"	1"

¹⁾ Please indicate dimension of the tube when ordering

Face-to-face acc. to data sheet resp. customer request										
L	(mm)	210	210	230	95	95	95	250	250	250

Dimensions		Standard-flange dimensions refer to page 23								
H	(mm)	98	98	98	98	98	103	98	98	98
S	(mm)	70	70	70	70	70	70	70	70	70
HEX	(mm)	50	50	50	50	50	50	50	50	50

Weights											
Fig. 600	(approx.)	(kg)	4,1	5,6	7	1,7	1,6	2,1	2,2	2,3	2,4

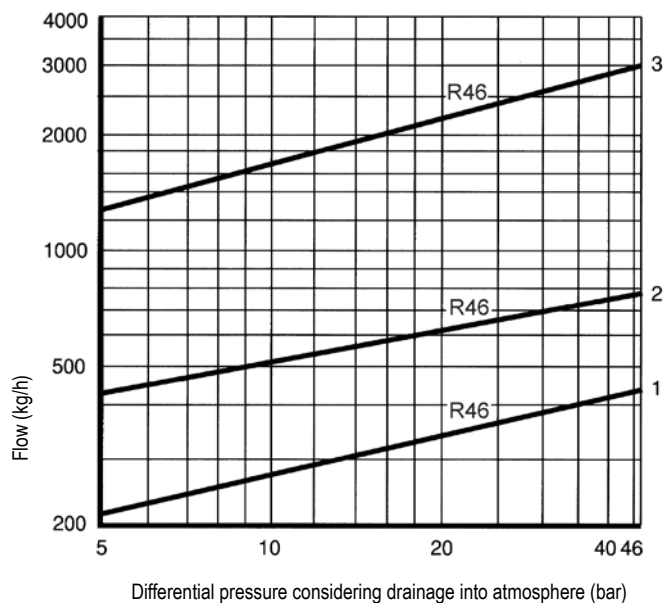
Parts			
Pos.	Sp.p.	Description	Fig. 86.600
1		Body	16Mo3, 1.5415
2	x	Strainer	X5CrNi18-10, 1.4301
6		Cap	16Mo3, 1.5415
24	x	Controller, cpl.	TB 102 / 85 (corrosion resistant bimetal)
		L Spare parts	

Information / restriction of technical rules need to be observed!

Resistance and fitness must be verified (contact manufacturer for information, refer to Product overview and Resistance list).

Operating and installation instructions can be downloaded at www.ari-armaturen.com.

Capacity chart



The capacity chart shows the maximum capacity at factory setting.

(For operating pressures below 5 bar, a correction of the factory-setting acc. to manufacturers information is recommended.)

Curve 1: Maximum flow of hot condensate approx. 15 K below saturation temperature.

Curve 2: Maximum flow of sub-cooled condensate at approx. 30 K below saturation temperature (with back-up of condensate).

Curve 3: Maximum flow at cold condensate at about 20°C (during start-up of a cold installation).

The condensate temperature determines the opening of the controller. Capacity is increased with the sub-cooling temperature of the condensate.

W. T. Maye, Inc.
 1-877-705-9864
info@wtmi-usa.com
www.wtmi-usa.com

High pressure - Bimetallic steam trap (High temperature steel)

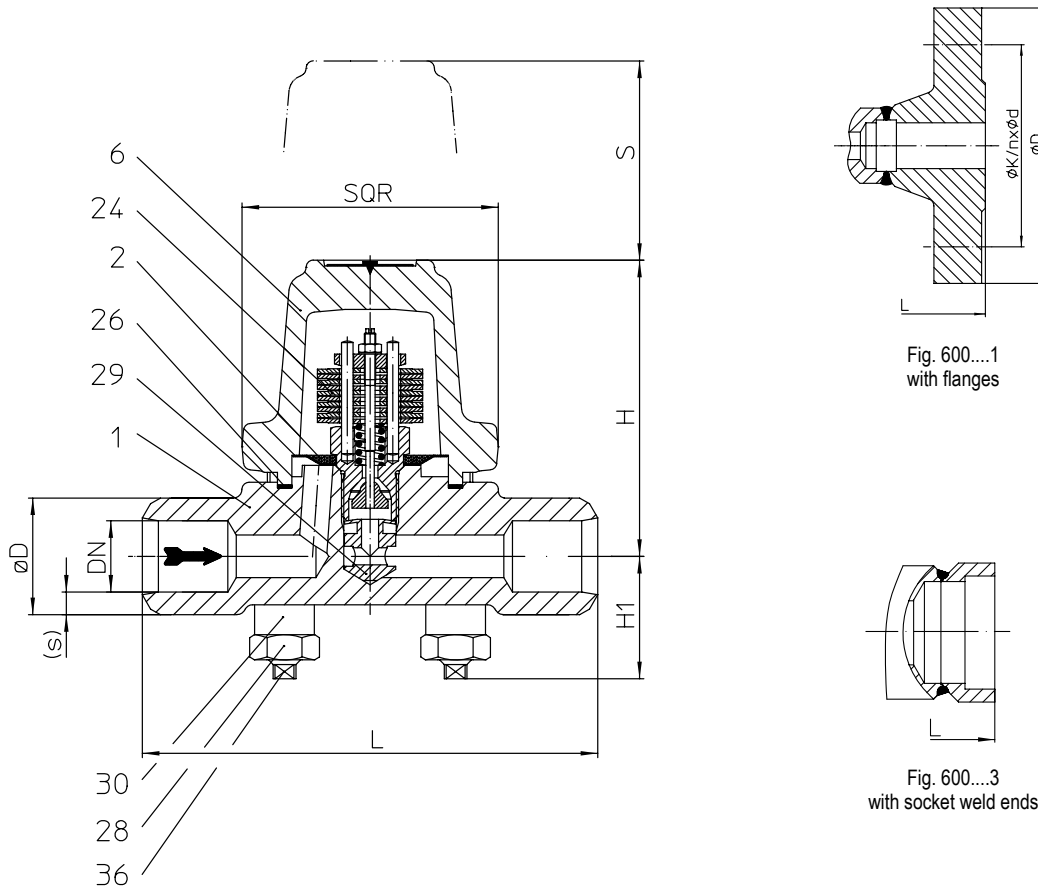


Fig. 600...4 with butt weld ends

Figure	Nominal pressure	Material	Nominal diameter / NPS	Operating pressure PS	Inlet temperature TS	allowable differential pressure ΔPMX	for controller
86.600	PN63	16Mo3	DN15-25 / 1/2" - 1"	56 barg	300 °C	56 bar	R56
				47 barg	400 °C		
				45 barg	450 °C		
87.600	PN100	16Mo3	DN15-25 / 1/2" - 1"	90 barg	450 °C	56 bar	R56
				56 barg	500 °C		90 bar
				27 barg	530 °C		

For ANSI versions refer to data sheet CONA®B-ANSI

Types of connection Other types of connection on request.

- Flanges1 _____ acc. to DIN EN 1092-1
- Socket weld ends3 _____ acc. to DIN EN 12760
- Butt weld ends4 _____ Weld preparation acc. to EN ISO 9692 identification No. 1.3 and 1.5
(Note restriction on operating pressure / inlet temperature depending to design!)

Features

- Thermostatic steam trap with non-corrosive and robust water hammer proof bimetallic controller
- Steam trap specially for high pressures
- Automatic air-venting during start up and operation of the plant
- Check valve
- With inside strainer
- Installation in any position, except cover downwards
- Subcooling of condensate is continuously adjustable (observe the operation instructions)
- The controller maybe changed without disturbing the pipe work

Controller (chooseable for operating range)

- Controller R56 up to inlet pressure: 56 bar
- Controller R90 up to inlet pressure: 90 bar

Types of connection	Flanges			Socket weld ends			Butt weld ends ¹⁾		
DN	15	20	25	15	20	25	15	20	25
NPS	1/2"	3/4"	1"	1/2"	3/4"	1"	1/2"	3/4"	1"

¹⁾ Please indicate dimension of the tube when ordering

Face-to-face acc. to data sheet resp. customer request										
L	(mm)	210	210	230	160	160	160	160	160	160

Dimensions										
Standard-flange dimensions refer to page 23 / Larger nominal diameters (PN63) refer to page 12.										
H	(mm)	104	104	104	104	104	104	104	104	104
H1	(mm)	42	42	42	42	42	42	42	42	42
S	(mm)	70	70	70	70	70	70	70	70	70
SQR	(mm)	90	90	90	90	90	90	90	90	90

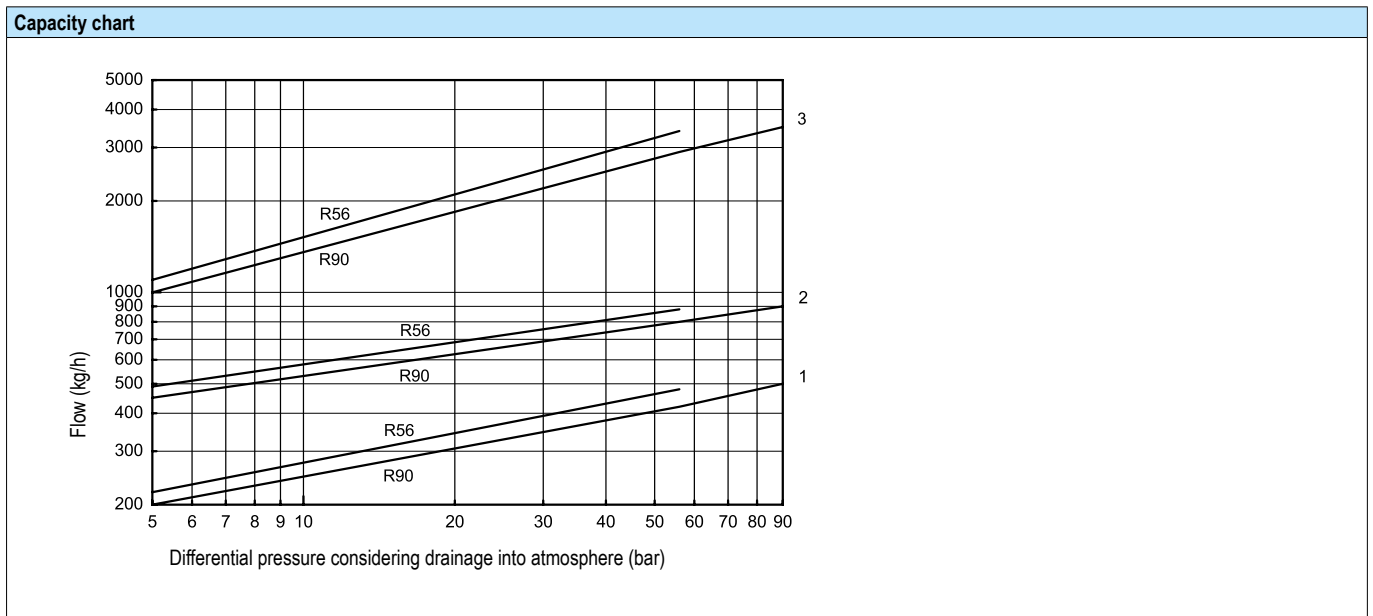
Weights											
Fig. 600	(approx.)	(kg)	6,2	7,7	9,3	4,6	4,5	4,4	4,6	4,5	4,4

Parts			
Pos.	Sp.p.	Description	Fig. 86.600 / 87.600
1		Body	16Mo3, 1.5415
2	x	Strainer	X5CrNi18-10, 1.4301
6		Cover	16Mo3, 1.5415
24	x	Controller, cpl.	TB 102 / 85 (corrosion resistant bimetal)
26	x	Gasket	Graphite (CrNi laminated with graphite)
28		Hexagonal nut	21CrMoV 5-7, 1.7709
29	x	Erosion deflector	X8CrNiS18-9, 1.4305
30		Extension sleeve	21CrMoV 5-7, 1.7709
36		Stud	21CrMoV 5-7, 1.7709
		L Spare parts	

Information / restriction of technical rules need to be observed!

Resistance and fitness must be verified (contact manufacturer for information, refer to Product overview and Resistance list).

Operating and installation instructions can be downloaded at www.ari-armaturen.com.



The capacity chart shows the maximum flow at factory setting.

(For operating pressures below 5 bar, a correction of the factory-setting acc. to manufacturers information is recommended.)

Curve 1: Maximum flow of hot condensate approx. 15 K below saturation temperature.

Curve 2: Maximum flow of sub-cooled condensate at approx. 30 K below saturation temperature (with back-up of condensate).

Curve 3: Maximum flow at cold condensate at about 20°C (during start-up of a cold installation).

The condensate temperature determines the opening of the controller. Capacity is increased with the sub-cooling temperature of the condensate.

High pressure - Bimetallic steam trap (High temperature steel)

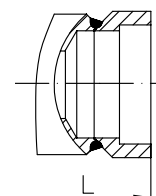
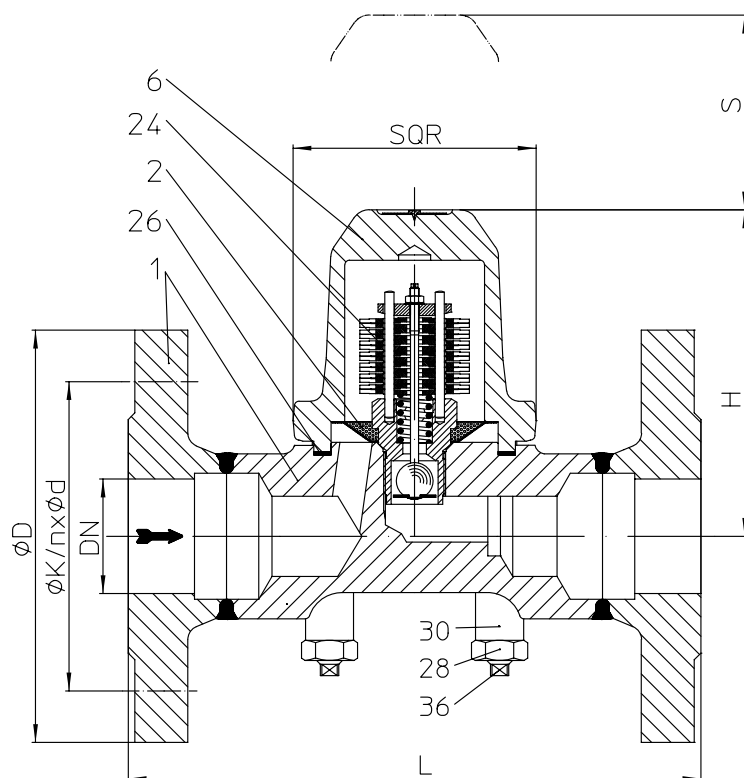
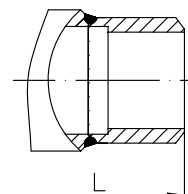

 Fig. 600...3
 with socket weld ends

 Fig. 600...4
 with butt weld ends

Fig. 600...1 with flanges

Figure	Nominal pressure	Material	Nominal diameter / NPS	Operating pressure PS	Inlet temperature TS	allowable differential pressure Δ PMX	for controller
86.600	PN63	16Mo3	DN40-50 / 1 1/2" - 2"	56 barg	300 °C	56 bar 32 bar	R56 R32
				50 barg	350 °C		
				45 barg	450 °C		

For ANSI versions refer to data sheet CONA®B-ANSI

Types of connection Other types of connection on request.

- Flanges1 _____ acc. to DIN EN 1092-1
- Socket weld ends3 _____ acc. to DIN EN 12760
- Butt weld ends4 _____ Weld preparation acc. to EN ISO 9692 identification No. 1.3 and 1.5
(Note restriction on operating pressure / inlet temperature depending to design!)

Features

- Thermostatic steam trap with non-corrosive and robust water hammer proof bimetallic controller
- Automatic air-venting during start up and operation of the plant
- Check valve
- With inside strainer
- Installation in any position, except cover downwards
- Subcooling of condensate is continuously adjustable (observe the operation instructions)
- The controller maybe changed without disturbing the pipe work

Controller
(chooseable for operating range)

- Controller R56 _____ up to inlet pressure: 56 bar
- Controller R32 _____ up to inlet pressure: 32 bar

Types of connection	Flanges		Socket weld ends		Butt weld ends ¹⁾	
DN	40	50	40	50	40	50
NPS	1 1/2"	2"	1 1/2"	2"	1 1/2"	2"

¹⁾ Please indicate dimension of the tube when ordering

Face-to-face acc. to data sheet resp. customer request							
L	(mm)	260	300	130	210	250	250

Dimensions		Standard-flange dimensions refer to page 23 / Smaller nominal diameters refer to page 10					
H	(mm)	144	144	144	144	144	144
S	(mm)	90	90	90	90	90	90
SQR	(mm)	110	110	110	110	110	110

Weights								
Fig. 600	(approx.)	(kg)	13,3	14,1	8	8	8,9	9,8

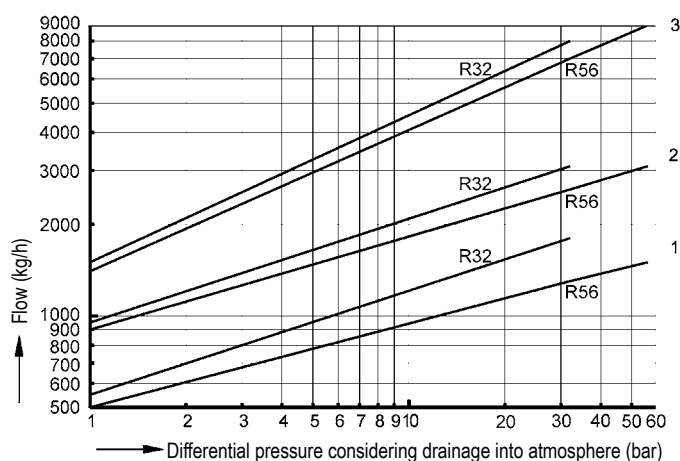
Parts			
Pos.	Sp.p.	Description	Fig. 86.600
1		Body	16Mo3, 1.5415
2	x	Strainer	X5CrNi18-10, 1.4301
6		Cover	16Mo3, 1.5415
24	x	Controller, cpl.	TB 102 / 85 (corrosion resistant bimetal)
26	x	Gasket	Graphite (CrNi laminated with graphite)
28		Hexagonal nut	21CrMoV 5-7, 1.7709
30		Extension sleeve	21CrMoV 5-7, 1.7709
36		Stud	21CrMoV 5-7, 1.7709
L Spare parts			

Information / restriction of technical rules need to be observed!

Resistance and fitness must be verified (contact manufacturer for information, refer to Product overview and Resistance list).

Operating and installation instructions can be downloaded at www.ari-armaturen.com.

Capacity chart



The capacity chart shows the maximum flow at factory setting.

(For operating pressures below 5 bar, a correction of the factory-setting acc. to manufacturers information is recommended.)

Curve 1: Maximum flow of hot condensate approx. 15 K below saturation temperature.

Curve 2: Maximum flow of sub-cooled condensate at approx. 30 K below saturation temperature (with back-up of condensate).

Curve 3: Maximum flow at cold condensate at about 20°C (during start-up of a cold installation).

The condensate temperature determines the opening of the controller. Capacity is increased with the sub-cooling temperature of the condensate.

W. T. Maye, Inc.
 1-877-705-9864
info@wtmi-usa.com
www.wtmi-usa.com

High pressure - Bimetallic steam trap (High temperature steel)

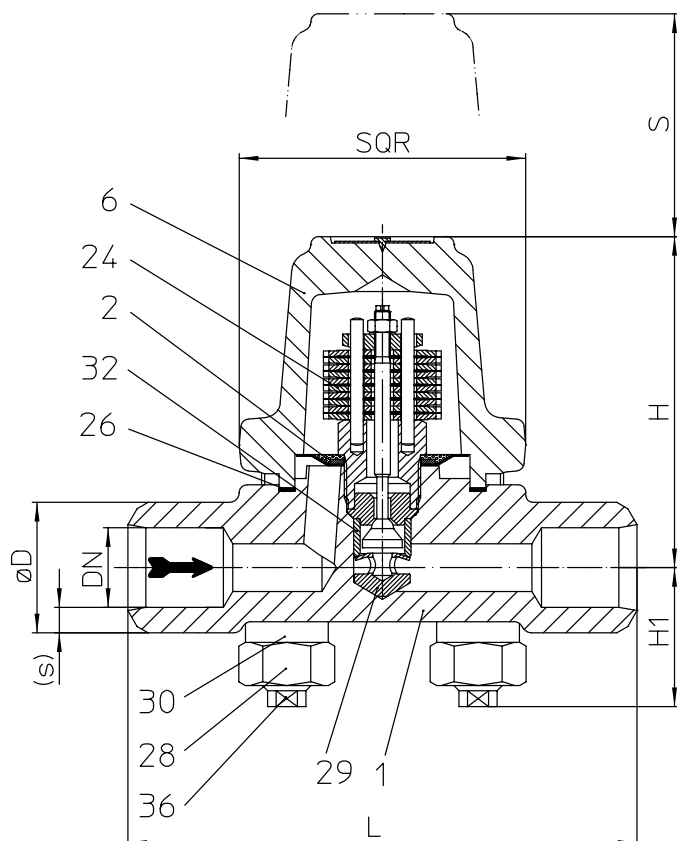


Fig. 600...4 with butt weld ends

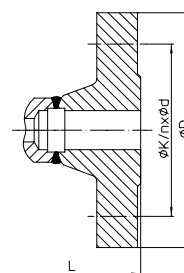
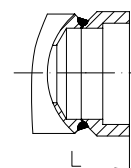

 Fig. 600...1
 with flanges

 Fig. 600...3
 with socket weld ends

Figure	Nominal pressure	Material	Nominal diameter / NPS	Operating pressure PS	Inlet temperature TS	allowable differential pressure ΔPMX	for controller
88.600	PN160	13CrMo4-5	DN15-25 / 1/2" - 1"	153 barg	350 °C	110 bar	R130
				100 barg	510 °C		
				62 barg	530 °C		
				35 barg	550 °C		
89.600	PN250	10CrMo9-10	DN15-25 / 1/2" - 1"	184 barg	500 °C	154 bar	R150
				154 barg	510 °C		
				108 barg	530 °C		
				81 barg	550 °C		

For ANSI versions refer to data sheet CONA®B-ANSI

Types of connection

Other types of connection on request.

- Flanges ...1 _____ acc. to DIN EN 1092-1
- Socket weld ends ...3 _____ acc. to DIN EN 12760
- Butt weld ends ...4 _____ Weld preparation acc. to EN ISO 9692 identification No. 1.3 and 1.5
 (Note restriction on operating pressure / inlet temperature depending to design!)

Features

- Thermostatic steam trap with non-corrosive and robust water hammer proof bimetallic controller
- **Steam trap specially for high pressures**
- Automatic air-venting during start up and operation of the plant
- Check valve
- With inside strainer
- Installation in any position, except cover downwards
- Subcooling of condensate is continuously adjustable (observe the operation instructions)
- The controller maybe changed without disturbing the pipe work

Controller

(chooseable for operating range)

- Controller R130 _____ up to inlet pressure: 110 bar
- Controller R150 _____ up to inlet pressure: 154 bar

Types of connection	Flanges		Socket weld ends			Butt weld ends ¹⁾		
DN	15	25	15	20	25	15	20	25
NPS	1/2"	1"	1/2"	3/4"	1"	1/2"	3/4"	1"

¹⁾ Please indicate dimension of the tube when ordering

Face-to-face acc. to data sheet resp. customer request									
L	(mm)	210	230	160	160	160	160	160	160

Dimensions		Standard-flange dimensions refer to page 23							
H	(mm)	104	104	104	104	104	104	104	104
H1	(mm)	42	42	42	42	42	42	42	42
S	(mm)	70	70	70	70	70	70	70	70
SQR	(mm)	90	90	90	90	90	90	90	90

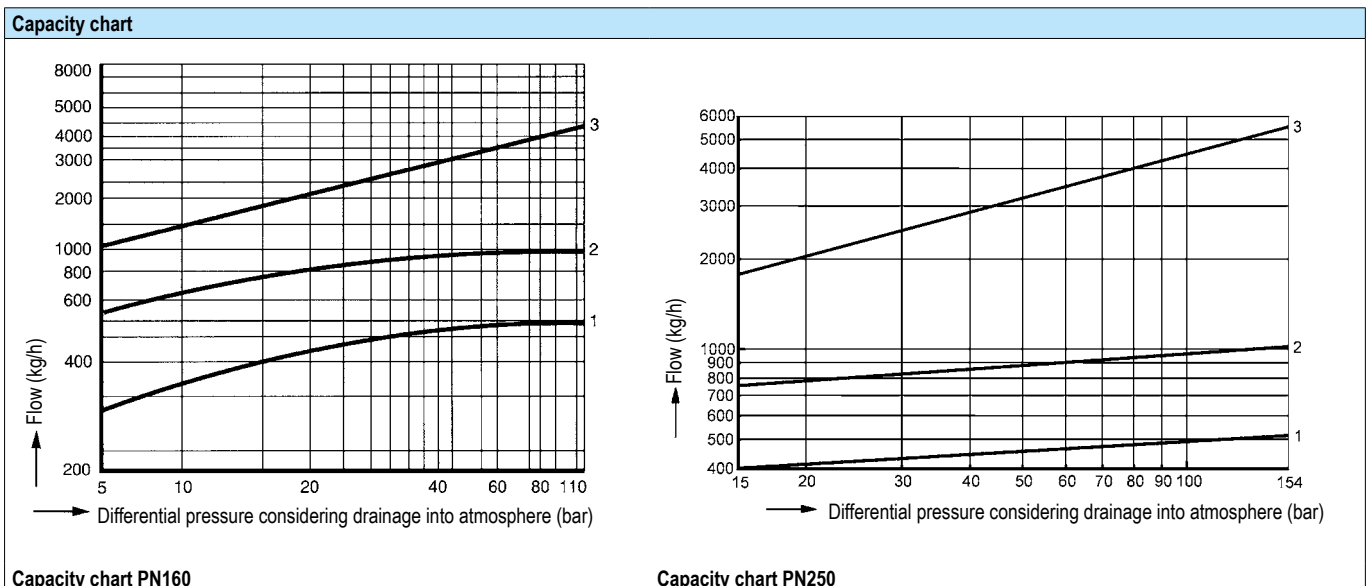
Weights										
Fig. 600	(approx.)	(kg)	6,4	9,6	4,8	4,7	4,6	4,8	4,7	4,6

Parts					
Pos.	Sp.p.	Description	Fig. 88.600	Fig. 89.600	
1		Body	13CrMo4-5, 1.7335	10CrMo9-10, 1.7380	
2	x	Strainer	X5CrNi18-10, 1.4301		
6		Cover	13CrMo4-5, 1.7335	10CrMo9-10, 1.7380	
24	x	Controller, cpl.	TB 102 / 85 (corrosion resistant bimetal)		
26	x	Gasket	Graphite (CrNi laminated with graphite)		
28		Hexagonal nut	21CrMoV 5-7, 1.7709	X22CrMoV12-1, 1.4923	
29	x	Erosion deflector	X8CrNiS18-9, 1.4305		
30		Extension sleeve	21CrMoV 5-7, 1.7709	X22CrMoV12-1, 1.4923	
32	x	Clamping sleeve	X39CrMo17-1+QT, 1.4122+QT		
36		Stud	21CrMoV 5-7, 1.7709	X22CrMoV12-1, 1.4923	
L Spare parts					

Information / restriction of technical rules need to be observed!

Resistance and fitness must be verified (contact manufacturer for information, refer to Product overview and Resistance list).

Operating and installation instructions can be downloaded at www.ari-armaturen.com.



The capacity chart shows the maximum capacity at factory setting.
 (For operating pressures below 15 bar, a correction of the factory-setting acc. to manufacturers information is recommended.)

Curve 1: Maximum flow of hot condensate at approx. 10 K below saturation temperature.
Curve 2: Maximum flow of sub-cooled condensate at approx. 30 K below saturation temperature (with back-up of condensate).
Curve 3: Maximum flow at cold condensate at about 20°C (during start-up of a cold installation).

The condensate temperature determines the opening of the controller. Capacity is increased with the sub-cooling temperature of the condensate.

W. T. Maye, Inc.
 1-877-705-9864
info@wtmi-usa.com
www.wtmi-usa.com

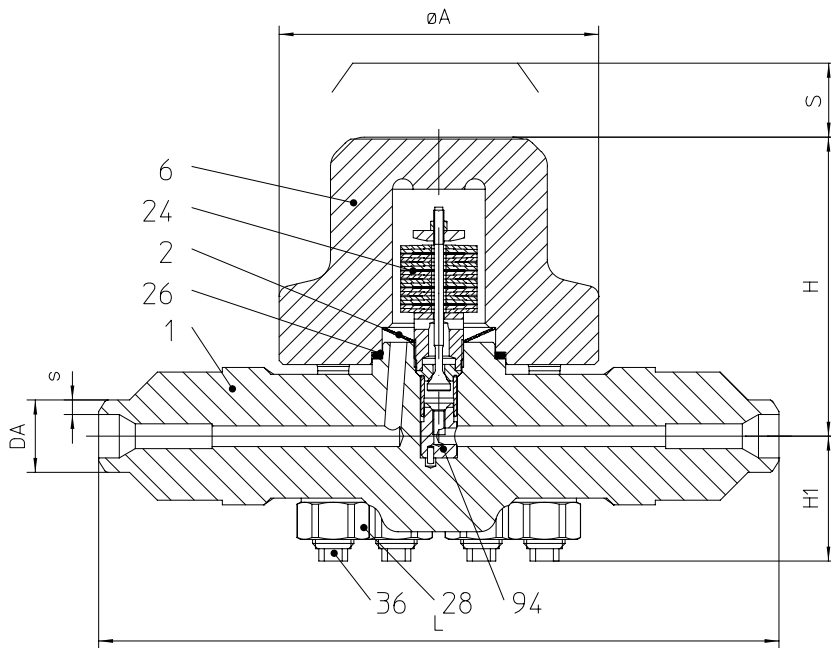
High pressure - Bimetallic steam trap (High temperature steel)


Fig. 600...4 with butt weld ends

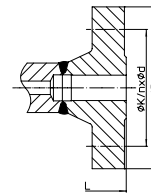
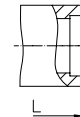

 Fig. 600...1 (PN320 / 400, 1.7383)
 with flanges

 Fig. 600...3
 with socket weld ends

Figure	Nominal pressure	Material	Nominal diameter / NPS	Operating pressure PMO	allowable differential pressure $\Delta PMN - \Delta PMX$	for controller
8a.600	PN320	11CrMo9-10, 1.7383	DN15-50 / 1/2" - 2"	220 bar(g)	15 - 220 bar	R220
8b.600	PN400	11CrMo9-10, 1.7383	DN15-50 / 1/2" - 2"	270 bar(g)	15 - 220 bar	R220
8c.600	PN630	11CrMo9-10, 1.7383	DN15-50 / 1/2" - 2"	320 bar(g)	15 - 270 bar	R270
					15 - 220 bar	R220
					15 - 320 bar	R320
		X10CrMo VNb9-1, 1.4903	DN15-50 / 1/2" - 2"	320 bar(g)	15 - 220 bar	R220
					15 - 270 bar	R270
					15 - 320 bar	R320
X10CrWMo VNb9-2, 1.4901	DN15-50 / 1/2" - 2"	320 bar(g)	15 - 220 bar	R220		
			15 - 270 bar	R270		
			15 - 320 bar	R320		

For ANSI versions refer to data sheet CONA®B-ANSI

Design pressure ¹⁾		Temperature (°C)																
Material	Figure	(barg)	300	350	400	450	460	470	480	490	500	510	520	530	540	550	560	570
1.7383	8a.600	(barg)	320	312	297	281	266	251	236	220	205	179	156	137	118	103	88	77
1.7383	8b.600	(barg)	400	390	371	352	333	314	295	276	257	224	196	171	148	129	110	97
Material	Figure	(barg)	Temperature (°C)															
1.7383	8c.600	(barg)	500	479	418	364	316	273	236	206	178	151	-	-	-	-	-	-
1.4903		(barg)	500	500	500	500	500	500	500	500	463	410	363	319	283	248	-	-
1.4901		(barg)	500	500	500	500	500	500	500	500	500	482	428	376	325	281	243	207

¹⁾ If the valve has a butt weld end connection, the maximum allowable design pressure depends on the outside diameter and the required wall thickness of the butt weld end. For the allowable design pressures for butt weld ends, refer to the "Butt weld end design pressures" table. Other butt weld end dimensions are available on request.

Features
<ul style="list-style-type: none"> • Thermostatic steam trap with non-corrosive and robust water hammer proof bimetallic controller • Steam trap specially for high pressures • Automatic air-venting during start up and operation of the plant • Check valve • With inside strainer • Installation in any position, except cover downwards • Subcooling of condensate is continuously adjustable (observe the operation instructions) • The controller maybe changed without disturbing the pipe work

Types of connection	Flanges					Socket weld ends					Butt weld ends ¹⁾				
DN / DA	15	20	25	40	50	15	20	25	40	50	21,3	26,9	33,7	48,3	60,3
NPS	1/2"	3/4"	1"	1 1/2"	2"	1/2"	3/4"	1"	1 1/2"	2"					

¹⁾ Butt weld ends with other outside diameters or other weld preparations on request

Available connection types															
Fig. 8a.600	x	-	x	x	x	x	x	x	x	-	x	x	x	x	x
Fig. 8b.600	x	-	x	x	-	x	x	x	-	-	x	x	x	x	x
Fig. 8c.600	-	-	-	-	-	x	x	x	-	-	x	x	x	x	x

- Flanges1 _____ acc. to DIN EN 1092-1
- Socket weld ends3 _____ acc. to DIN EN 12760
- Butt weld ends4 _____ Weld preparation acc. to ISO 9692 identification No. 1.3, $\alpha = 60^\circ$

Face-to-face acc. to data sheet resp. customer request																
L	(mm)	435	--	470	490	510	330	330	330	330	--	330	330	330	330	330

Dimensions																
H	(mm)	144	--	144	144	144	144	144	144	144	--	144	144	144	144	144
H1	(mm)	61	--	61	61	61	61	61	61	61	--	61	61	61	61	61
S	(mm)	95	--	95	95	95	95	95	95	95	--	95	95	95	95	95
A	(mm)	155	--	155	155	155	155	155	155	155	--	155	155	155	155	155

Standard-flange dimensions refer to page 23

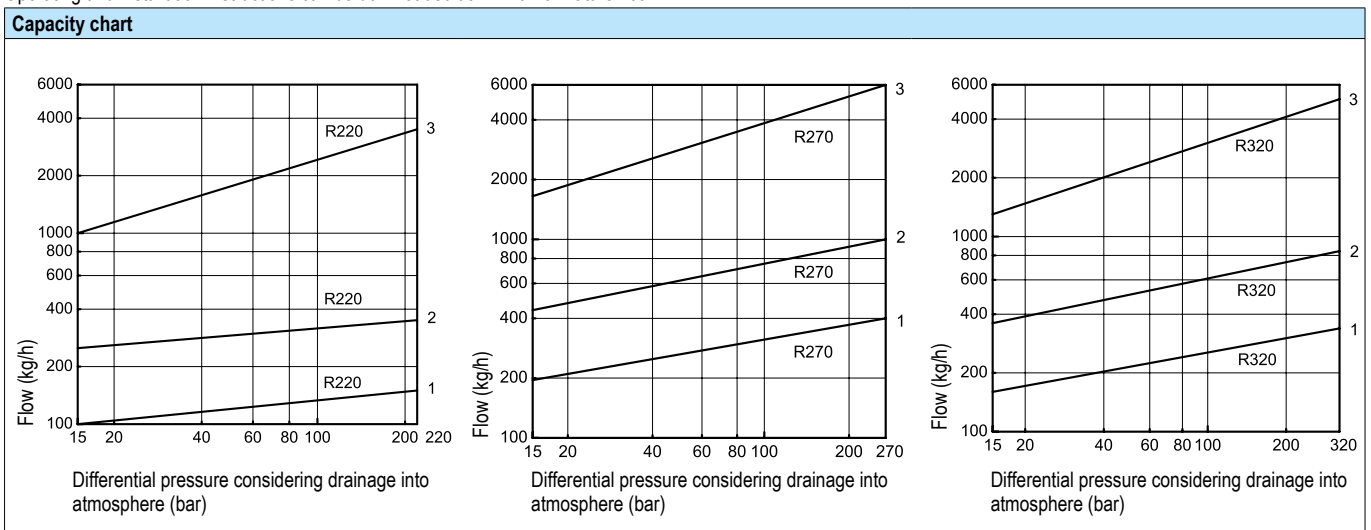
Weights																
Fig. 600 (approx.)	PN320	(kg)	29	--	34	41	44	24	24	24	24	--	24	24	24	24
	PN400	(kg)	31	--	39	52	--									
	PN630	(kg)	--	--	--	--	--									

Parts					
Pos.	Sp.p.	Description	Fig. 8a.600 / 8b.600 / 8c.600	Fig. 8c.600	Fig. 8c.600
1		Body	11CrMo9-10, 1.7383	X10CrMoVNb9-1, 1.4903	X10CrWMoVNb9-2, 1.4901
2	x	Strainer	X5CrNi18-10, 1.4301		
6		Cover	11CrMo9-10, 1.7383	X10CrMoVNb9-1, 1.4903	X10CrWMoVNb9-2, 1.4901
24	x	Controller, cpl.	TB 102 / 85 (corrosion resistant bimetal)		
26	x	Spiral gasket	MICA/RGF (CrNi laminated with graphite)		
28		Hexagonal nut	X22CrMoV12-1, 1.4923	X7CrNiMoBNb16-16, 1.4986	
36		Stud	X22CrMoV12-1, 1.4923	X7CrNiMoBNb16-16, 1.4986	
94	x	Erosion deflector, cpl.	X39CrMo17-1+QT, 1.4122+QT		
L Spare parts					

Information / restriction of technical rules need to be observed!

Resistance and fitness must be verified (contact manufacturer for information, refer to Product overview and Resistance list).

Operating and installation instructions can be downloaded at www.ari-armaturen.com.



The capacity chart shows the maximum capacity at factory setting.

(For operating pressures below 15 bar, a correction of the factory-setting acc. to manufacturers information is recommended.)

Curve 1: Maximum flow of hot condensate at approx. 10 K below saturation temperature.

Curve 2: Maximum flow of sub-cooled condensate at approx. 30 K below saturation temperature (with back-up of condensate).

Curve 3: Maximum flow at cold condensate at about 20°C (during start-up of a cold installation).

The condensate temperature determines the opening of the controller. Capacity is increased with the sub-cooling temperature of the condensate.

Butt weld end design pressures acc. to the outside diameter and wall thickness, material 1.7383																		
Temperature °C		350	400	450	460	470	480	490	500	510	520	530	540	550	560	570	580	590
DA	s	Design pressure PMA, bar(g)																
21,3	6,3	500	500	500	500	500	500	500	490	428	374	325	283	244	211	184	159	139
	5,6	500	500	500	500	500	500	476	419	366	320	278	242	208	180	157	136	119
	5,0	500	500	500	500	500	479	427	376	328	287	249	217	187	162	141	122	107
	4,5	500	489	464	459	449	404	360	317	277	242	211	183	153	136	119	103	90
	4,0	430	409	388	383	375	337	301	265	231	202	176	153	132	114	99	86	75
	3,6	360	342	324	321	314	282	252	222	194	169	147	128	110	95	83	72	63
	3,2	295	280	266	263	257	231	206	182	159	138	120	105	90	78	68	59	51
	2,9	250	237	225	223	218	196	175	154	134	117	102	89	76	66	57	50	43
26,9	8,0	500	500	500	500	500	500	500	500	452	395	344	299	258	223	194	168	147
	7,1	500	500	500	500	500	500	500	444	388	338	295	256	221	191	166	144	126
	6,3	500	500	500	500	500	500	455	401	350	305	266	231	199	172	150	130	114
	5,6	500	500	491	486	475	428	381	336	293	256	223	194	167	144	126	109	95
	5,0	460	437	415	410	401	361	322	283	247	216	188	163	141	122	106	92	80
	4,5	395	375	356	352	344	310	276	243	212	185	161	140	121	105	91	79	69
	4,0	330	313	297	294	288	259	231	203	177	155	135	117	101	87	76	66	57
	3,6	275	261	248	245	240	215	192	169	148	129	112	97	84	73	63	55	48
3,2	230	218	207	205	200	180	161	141	123	108	94	81	70	61	53	46	40	
33,7	10,0	500	500	500	500	500	500	500	500	466	407	354	308	265	230	200	173	151
	8,8	500	500	500	500	500	500	500	456	398	348	303	263	227	196	171	148	129
	8,0	500	500	500	500	500	500	490	431	377	329	286	249	215	186	162	140	122
	7,1	500	500	500	500	500	463	413	364	318	277	241	210	181	156	136	118	103
	6,3	495	470	446	441	432	388	346	305	266	233	202	176	152	131	114	99	86
	5,6	420	399	379	374	366	329	294	259	226	197	172	149	129	111	97	84	73
	5,0	355	337	320	316	309	278	248	219	191	167	145	126	109	94	82	71	62
	4,5	305	290	275	272	266	239	213	188	164	143	124	108	93	81	70	61	53
	4,0	255	242	230	227	222	200	178	157	137	120	104	90	78	67	59	51	44
48,3	14,2	500	500	500	500	500	500	500	500	479	418	364	316	273	236	206	178	151
	12,5	500	500	500	500	500	500	500	475	415	362	315	274	236	204	178	154	135
	11,0	500	500	500	500	500	500	490	431	377	329	286	249	215	186	162	140	122
	10,0	500	500	500	500	500	483	430	379	331	289	252	219	189	163	142	123	108
	8,8	500	489	464	459	449	404	360	317	277	242	211	183	158	136	119	103	90
	8,0	455	432	410	406	397	357	318	280	245	214	186	162	139	120	105	91	79
	7,1	385	366	347	343	336	302	269	237	207	181	157	137	118	102	89	77	67
	6,3	325	309	293	290	283	255	227	200	175	152	133	115	99	86	75	65	57
	5,6	280	266	252	249	244	219	196	172	150	131	114	99	86	74	64	56	49
	5,0	240	228	216	214	209	188	168	148	129	112	98	85	73	63	55	48	42
60,3	17,5	500	500	500	500	500	500	500	500	479	418	364	316	273	236	206	178	151
	16,0	500	500	500	500	500	500	500	496	433	378	329	286	247	214	186	161	141
	14,2	500	500	500	500	500	500	490	431	377	329	286	249	215	186	162	140	122
	12,5	500	500	500	500	500	498	444	391	342	298	260	226	195	168	147	127	111
	11,0	500	500	482	477	467	420	374	330	288	251	219	190	164	142	123	107	93
	10,0	470	447	424	419	410	369	329	290	253	221	192	167	144	124	108	94	82
	8,8	400	380	360	357	349	314	280	246	215	188	163	142	122	106	92	80	70
	8,0	350	332	315	312	305	274	245	215	188	164	143	124	107	93	81	70	61
	7,1	300	285	270	267	261	235	210	185	161	141	122	106	92	79	69	60	52
	6,3	255	242	230	227	222	200	178	157	137	120	104	90	78	67	59	51	44

Butt weld end design pressures acc. to the outside diameter and wall thickness, material 1.4903																		
Temperature °C	350	400	450	500	510	520	530	540	550	560	570	580	590	600	610	620	630	
DA	s	Design pressure PMA, bar(g)																
21,3	6,3	500	500	500	500	500	500	500	500	500	500	493	438	388	343	302	268	235
	5,6	500	500	500	500	500	500	500	500	500	471	421	375	332	294	259	229	201
	5,0	500	500	500	500	500	500	500	500	470	422	377	336	297	263	232	205	180
	4,5	500	500	500	500	500	500	485	441	399	359	321	285	252	223	197	174	153
	4,0	500	500	500	500	481	441	403	366	331	298	266	237	209	185	163	144	127
	3,6	500	500	500	439	405	372	339	3058	279	251	224	199	176	156	137	122	107
	3,2	500	494	465	361	333	306	279	253	229	206	184	164	145	128	113	100	88
	2,9	428	415	391	303	280	257	234	213	193	173	155	138	122	108	95	84	74
26,9	8,0	500	500	500	500	500	500	500	500	500	500	500	463	409	362	319	282	248
	7,1	500	500	500	500	500	500	500	500	500	499	447	397	352	311	274	242	213
	6,3	500	500	500	500	500	500	500	500	500	452	405	360	319	282	248	220	193
	5,6	500	500	500	500	500	500	500	467	4223	380	340	302	267	236	208	184	162
	5,0	500	500	500	500	500	473	431	392	355	319	285	254	224	198	175	155	136
	4,5	500	500	500	476	440	403	368	334	302	272	243	216	191	169	149	132	116
	4,0	500	500	500	398	367	337	307	279	253	227	203	181	160	141	125	110	97
	3,6	474	460	433	336	311	285	260	236	214	192	172	153	135	119	105	93	82
3,2	393	382	359	279	257	236	215	196	177	159	142	127	112	99	87	77	68	
33,7	10,0	500	500	500	500	500	500	500	500	500	500	500	463	409	362	319	282	248
	8,8	500	500	500	500	500	500	500	500	500	500	459	409	361	320	282	249	219
	8,0	500	500	500	500	500	500	500	500	500	485	434	386	342	302	266	236	207
	7,1	500	500	500	500	500	500	500	500	454	408	365	324	287	254	224	198	174
	6,3	500	500	500	500	500	500	466	423	383	345	308	274	242	215	189	167	147
	5,6	500	500	500	500	470	431	393	357	323	291	260	231	204	181	159	141	124
	5,0	500	500	500	431	398	365	333	302	274	246	220	196	173	153	135	119	105
	4,5	500	500	476	369	341	313	285	259	235	211	188	168	148	131	116	102	90
	4,0	433	421	396	308	284	260	238	216	195	176	157	140	123	109	96	85	75
48,3	14,2	500	500	500	500	500	500	500	500	500	500	500	463	410	363	319	283	248
	12,5	500	500	500	500	500	500	500	500	500	500	476	423	375	332	292	258	227
	11,0	500	500	500	500	500	500	500	500	500	485	434	386	342	302	266	236	207
	10,0	500	500	500	500	500	500	500	500	475	427	382	339	300	266	234	207	182
	8,8	500	500	500	500	500	500	482	438	396	356	319	283	251	222	195	173	152
	8,0	500	500	500	500	500	466	425	386	349	314	281	250	221	196	172	152	134
	7,1	500	500	500	468	432	396	361	328	297	267	239	212	188	166	146	130	114
	6,3	500	500	500	398	367	337	307	279	253	227	203	181	160	141	125	110	97
	5,6	474	460	433	336	311	285	260	236	214	192	172	153	135	119	105	93	82
	5,0	404	393	370	287	265	243	222	201	182	164	146	130	115	102	90	79	70
60,3	17,5	500	500	500	500	500	500	500	500	500	500	500	463	410	363	319	283	248
	16,0	500	500	500	500	500	500	500	500	500	500	500	446	395	349	308	272	239
	14,2	500	500	500	500	500	500	500	500	500	485	434	386	342	302	266	236	207
	12,5	500	500	500	500	500	500	500	500	490	441	394	351	310	275	242	214	188
	11,0	500	500	500	500	500	500	500	455	412	370	331	295	261	231	203	180	158
	10,0	500	500	500	500	500	483	441	400	363	326	291	259	229	203	179	158	139
	8,8	500	500	500	484	447	410	374	340	308	276	247	220	195	172	152	134	118
	8,0	500	500	500	427	394	361	330	299	271	244	218	194	171	152	134	118	104
	7,1	500	500	470	365	337	309	282	256	232	208	186	166	147	130	114	101	89
	6,3	439	427	401	312	288	264	241	219	198	178	159	141	125	111	97	86	76

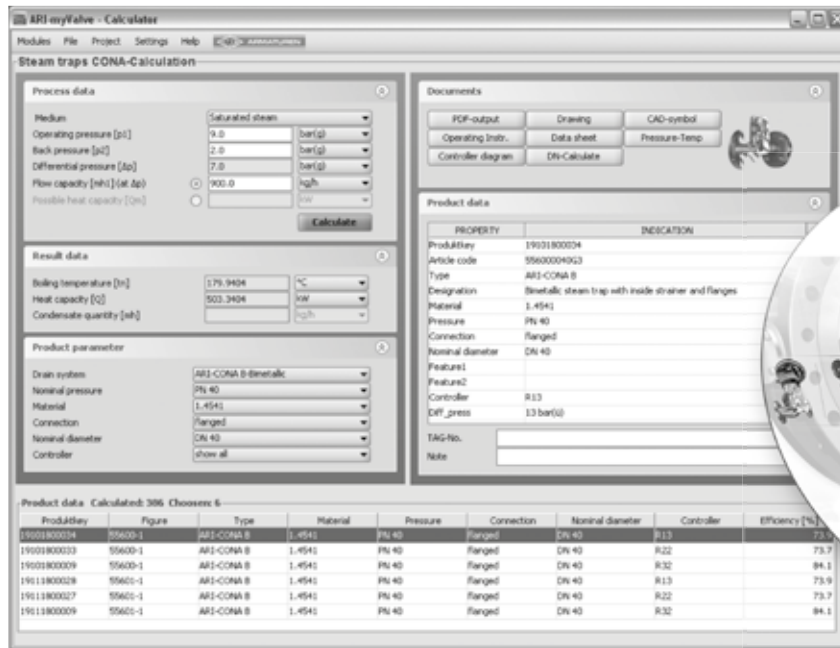
W. T. Maye, Inc.
1-877-705-9864
info@wtmi-usa.com
www.wtmi-usa.com

Butt weld end design pressures acc. to the outside diameter and wall thickness, material 1.4901																		
Temperatur °C	400	450	500	520	530	540	550	560	570	580	590	600	610	620	630	640	650	
DA	s	Design pressure PMA, bar(g)																
21,3	6,3	500	500	500	500	500	500	500	500	500	500	466	413	363	314	271	234	200
	5,6	500	500	500	500	500	500	500	500	496	446	398	353	310	268	232	200	171
	5,0	500	500	500	500	500	500	500	485	441	396	354	314	275	239	206	178	152
	4,5	500	500	500	500	500	490	453	415	377	339	302	268	236	204	176	152	130
	4,0	500	500	500	474	440	407	376	344	313	282	251	223	196	169	146	126	108
	3,6	500	500	500	400	371	343	317	290	264	237	212	188	165	143	123	106	91
	3,2	500	500	495	329	305	283	261	239	217	195	174	155	136	117	101	88	75
	2,9	455	440	415	277	256	237	219	201	182	164	146	130	114	99	85	74	63
26,9	8,0	500	500	500	500	500	500	500	500	500	500	482	428	376	325	281	243	207
	7,1	500	500	500	500	500	500	500	500	475	424	376	330	286	247	213	182	152
	6,3	500	500	500	500	500	500	500	500	476	428	382	339	297	257	222	192	164
	5,6	500	500	500	500	500	500	477	437	397	357	319	283	248	215	186	160	137
	5,0	500	500	500	500	473	438	404	370	336	302	270	239	210	182	157	136	116
	4,5	500	500	500	435	403	373	345	316	287	258	230	204	179	155	134	116	99
	4,0	500	500	500	360	334	309	285	261	238	214	191	169	148	128	111	96	82
	3,6	500	489	462	307	285	264	243	223	203	182	163	144	127	110	95	82	70
3,2	418	405	382	255	236	219	202	185	168	151	135	119	105	91	78	68	58	
33,7	10,0	500	500	500	500	500	500	500	500	500	500	482	428	376	325	281	243	207
	8,8	500	500	500	500	500	500	500	500	485	433	384	337	292	252	218	186	156
	8,0	500	500	500	500	500	500	500	500	459	410	363	319	276	239	206	176	148
	7,1	500	500	500	500	500	500	500	472	429	386	344	306	268	232	201	173	148
	6,3	500	500	500	500	500	472	435	399	362	326	291	258	226	196	169	146	125
	5,6	500	500	500	461	428	396	365	335	304	274	244	217	190	165	142	123	105
	5,0	500	500	500	391	362	336	310	284	258	232	207	184	161	139	120	104	89
	4,5	500	500	500	338	313	290	268	245	223	201	179	159	139	121	104	90	77
	4,0	462	447	422	281	260	241	223	204	185	167	149	132	116	100	86	75	64
48,3	14,2	500	500	500	500	500	500	500	500	500	500	482	428	376	325	281	243	207
	12,5	500	500	500	500	500	500	500	500	500	500	449	399	350	303	262	226	193
	11,0	500	500	500	500	500	500	500	500	462	412	366	321	278	240	207	177	148
	10,0	500	500	500	500	500	500	500	495	449	404	361	320	281	243	210	182	155
	8,8	500	500	500	500	500	490	453	415	377	339	302	268	236	204	176	152	130
	8,0	500	500	500	500	464	430	397	364	330	297	265	235	206	179	154	133	114
	7,1	500	500	500	426	395	366	338	309	281	253	226	200	176	152	131	113	97
	6,3	500	500	500	360	334	309	285	261	238	214	191	169	148	128	111	96	82
	5,6	500	489	462	307	285	264	243	223	203	182	163	144	127	110	95	82	70
	5,0	433	419	396	263	244	226	209	191	174	156	139	124	108	94	81	70	60
60,3	17,5	500	500	500	500	500	500	500	500	500	500	482	428	376	325	281	243	207
	16,0	500	500	500	500	500	500	500	500	500	500	473	419	368	319	275	238	203
	14,2	500	500	500	500	500	500	500	500	459	410	363	319	276	239	206	176	148
	12,5	500	500	500	500	500	500	500	500	464	417	372	330	290	251	217	187	160
	11,0	500	500	500	500	500	500	467	428	388	349	312	277	243	210	182	157	134
	10,0	500	500	500	500	481	445	411	376	342	308	274	244	214	185	160	138	118
	8,8	500	500	500	439	407	377	348	319	290	261	233	206	181	157	135	117	100
	8,0	500	500	500	387	358	332	306	281	255	229	205	181	159	138	119	103	88
	7,1	500	500	495	329	305	283	261	239	217	195	174	155	136	117	101	88	75
	6,3	462	447	422	281	260	241	223	204	185	167	149	132	116	100	86	75	64

W. T. Maye, Inc.
1-877-705-9864
info@wtmi-usa.com
www.wtmi-usa.com

myValve® - Your Valve Sizing-Program.

myValve is a powerful software tool that not only helps you size your system components; it also gives you instant access to all other data about the selected product, such as order information, spare parts drawings, operating instructions, data sheets, etc., whenever you need it.


myValve - Valve Sizing-Program
Contents:
Module ARI-Steam trap CONA-Calculation

- Sizing (calculation of steam trap systems with given flow capacity or heat capacity)
- Calculation of nominal diameter acc. to given pressure, condensate quantity, condensate sub-cooling and speed

Media:

- Steam (saturated and superheated)
- Compressed air

Special Features

- Project administration of the calculation and product data incl. spare part drawings concerning to project and tag number
- Direct output or calculation and product data in PDF format
- Product data could be taken for a direct order
- SI- and ANSI-units with direct conversion to another databank
- Settings with over pressure or absolute pressure
- All ARI products are integrated in one databank
- Direct access concerning to the product on data sheets, operating instructions, pressure-temperature-diagram and spare part drawings
- Operation in company networks possible (no complex installations on individually PC's necessary)
- Extensive catalogue extending over several product groups

System Requirements:

Windows operating systems, Linux, etc.

W. T. Maye, Inc.
 1-877-705-9864
 info@wtmi-usa.com
 www.wtmi-usa.com

Informations about pipe welding
Welding groove acc. to DIN 2559

The material used for ARI valves with butt weld ends are:	1.0619+N	GP240GH+N acc. to DIN EN 10213-2
	1.0460	P250GH acc. to DIN EN 10222-2
	1.0401	C15 acc. to DIN EN 10277-2
Note:	1.5415	16Mo3 acc. to DIN EN 10222-2
Note restriction on operating pressure / inlet temperature depending to design!	1.4541	X6CrNiTi18-10 acc. to DIN EN 10222-5
	1.7335	13CrMo4-5 acc. to DIN EN 10222-2
	1.7380	10CrMo 9-10 acc. to DIN EN 17243
	1.4903	X10CrMoVNb 91 acc. to DIN EN 10222-2
	1.4901	X10CrWMoVNb9-2, 1.4901 acc. to VdTÜV Data sheet 552/3

Due to our experience, we recommend to apply an electric welding process.

Because of the different material compositions and wall thickness of the steam traps and the pipe gas welding shall not be applied. Quenching cracks and coarse grain structure may develop.

On bimetallic steam traps face-to-face of 95 mm or less, the bimetallic controller has to be disassembled prior to welding. After the traps have cooled down to the ambient temperature the bimetallic controller shall be fitted again into the body.

Steam traps with socket-weld ends shall only be welded by arc welding (welding process 111 acc. to DIN EN 24063).

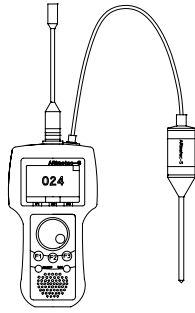
If during the time of warranty others than the manufacturer or by the manufacturer authorized persons are interfering in the product and/or the setting, the right of claim for warranty will lapse!

Standard-flange dimensions acc. to DIN EN 1092-1 / -2

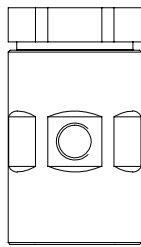
DN			15	20	25	32	40	50
NPS			1/2"	3/4"	1"	1 1/4"	1 1/2"	2"
PN16	ØD	(mm)	95	105	115	140	150	165
	ØK	(mm)	65	75	85	100	110	125
	n x Ød	(mm)	4 x 14	4 x 14	4 x 14	4 x 18	4 x 18	4 x 18
PN40	ØD	(mm)	95	105	115	140	150	165
	ØK	(mm)	65	75	85	100	110	125
	n x Ød	(mm)	4 x 14	4 x 14	4 x 14	4 x 18	4 x 18	4 x 18
PN63	ØD	(mm)	105	130	140	--	170	180
	ØK	(mm)	75	90	100	--	125	135
	n x Ød	(mm)	4 x 14	4 x 18	4 x 18	--	4 x 22	4 x 22
PN100	ØD	(mm)	105	130	140	--	--	--
	ØK	(mm)	75	90	100	--	--	--
	n x Ød	(mm)	4 x 14	4 x 16	4 x 18	--	--	--
PN160	ØD	(mm)	105	--	140	--	--	--
	ØK	(mm)	75	--	100	--	--	--
	n x Ød	(mm)	4 x 14	--	4 x 18	--	--	--
PN250	ØD	(mm)	130	--	150	--	--	--
	ØK	(mm)	90	--	105	--	--	--
	n x Ød	(mm)	4 x 18	--	4 x 22	--	--	--
PN320	ØD	(mm)	130	--	160	--	195	210
	ØK	(mm)	90	--	115	--	145	160
	n x Ød	(mm)	4 x 18	--	4 x 22	--	4 x 26	8 x 26
PN400	ØD	(mm)	145	--	180	--	220	--
	ØK	(mm)	100	--	130	--	165	--
	n x Ød	(mm)	4 x 22	--	4 x 26	--	4 x 30	--

W. T. Maye, Inc.
 1-877-705-9864
 info@wtmi-usa.com
 www.wtmi-usa.com

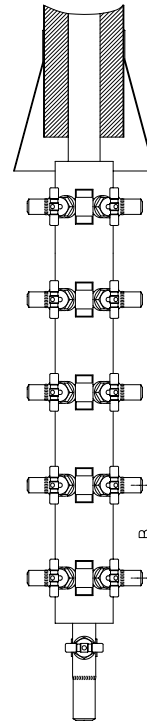
Selection criteria:	Example for order data:
<ul style="list-style-type: none"> • Steam pressure • Back pressure • Quantity of condensate • Nominal diameter / pressure 	<ul style="list-style-type: none"> • Pipe-connection • Controller • Material • Place of service or kind of steam consumer <p>Bimetallic steam trap CONA® B, Fig. 600, PN40, DN15, 1.0460, Controller R22, with flanges, Face-to-face dimension 150 mm</p>



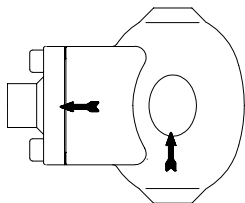
Multifunction tester
ARImetec®-S



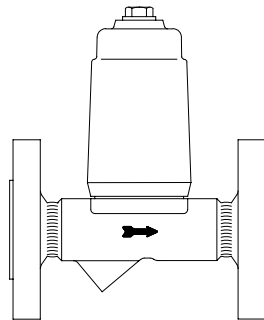
Vacuum breaker
Fig. 655



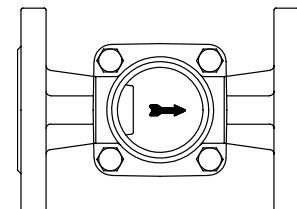
Condensate collection (B = 160), steam distribution (B = 120)
CODI®S with gland packing Fig. 671/672;
CODI®B with bellows seal, maintenance-free Fig. 675/676



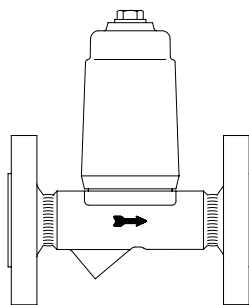
Automatic air vent for liquid systems
Fig. 656



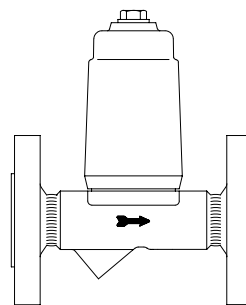
Condensate discharge temperature limiter
Fig. 645/647



Flow indicator
Fig. 660/661



Return temperature limiter
Fig. 650



Liquid drainer
Fig. 665

(Further informations about the accessories can be found in the appropriate data sheets.)

W. T. Maye, Inc.
1-877-705-9864
info@wtmi-usa.com
www.wtmi-usa.com



ISO 9001



WHG §19 I

