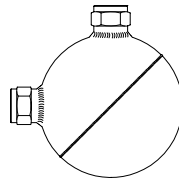


Ball float steam trap

**Ball float steam trap  
PN16**

- with screwed sockets

(Fig. 629....2)



Stainless steel  
Fig. 629

Page 2

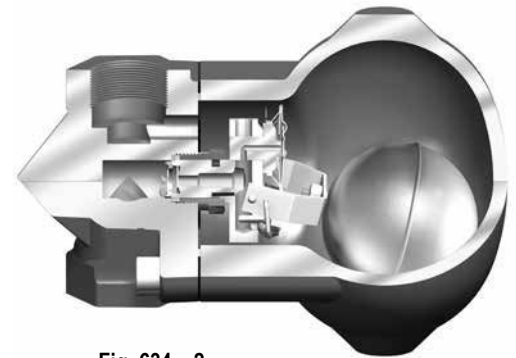


Fig. 634....2

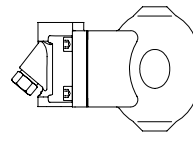
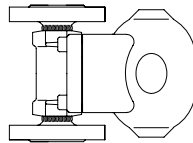
**CONA® SC**

**Ball float steam trap  
with capsule for rapid system start-up  
PN16 / PN25 / PN40**

- with flanges
- with screwed sockets
- with socket weld ends
- with butt weld ends

(Fig. 634....1)  
(Fig. 634....2)  
(Fig. 634....3)  
(Fig. 634....4)

Forged steel/  
SG iron  
Forged steel/  
Cast steel  
Stainless steel  
Fig. 634



Page 4



Fig. 635....1

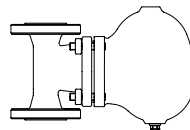
**CONA® SC Plus**

**Ball float steam trap  
with capsule for rapid system start-up  
PN16 / PN40**

- with flanges
- with screwed sockets

(Fig. 635....1)  
(Fig. 635....2)

Grey cast iron  
SG iron  
Forged steel  
Stainless steel  
Fig. 635



Page 6

**CONA® SC**

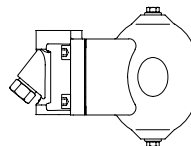
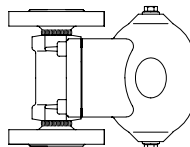
**Ball float steam trap for drainage of water  
from compressed air and gas systems  
(acc. to PED 2014/68/EU fluid group 2)**

**PN16 / PN25 / PN40**

- with flanges
- with screwed sockets
- with socket weld ends
- with butt weld ends

(Fig. 636....1)  
(Fig. 636....2)  
(Fig. 636....3)  
(Fig. 636....4)

Forged steel/  
SG iron  
Forged steel/  
Cast steel  
Stainless steel  
Fig. 636



Page 8

**Features:**

- Back pressure-free condensate discharge even at extreme pressure- and quantity fluctuations
- Controller with integrated automatic ventilation (except Fig. 629/636)
- Robust and insensitive to waterhammer
- Non return protection (except Fig. 629/635)
- Union for pressure compension line and bypass possible (except Fig. 629)
- On-site change of the installation position is possible according to the operating instructions (except Fig. 629)
- The controller maybe changed without disturbing the pipe work (except Fig. 629)

W. T. Maye, Inc.  
1-877-705-9864  
info@wtmi-usa.com  
www.wtmi-usa.com

**Ball float steam trap (Stainless steel)**

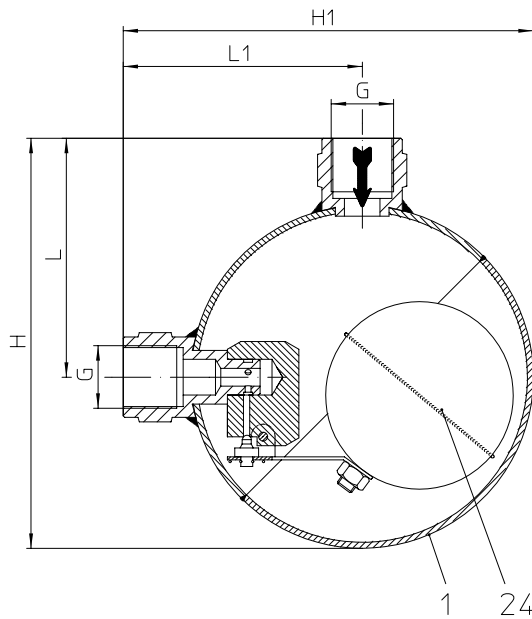
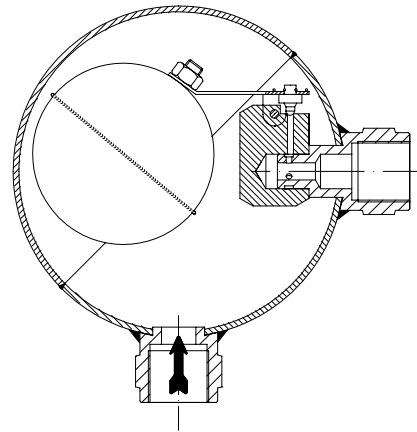


Fig. 629....2 with screwed sockets



Also as automatic air vent with inlet from the bottom useable (refer to Fig. 656)

Figure	Nominal pressure	Material	Nominal diameter / NPS	Operating pressure PS	Inlet temperature TS	allowable differential pressure $\Delta PMX$	for controller
52.629	PN16	Body: 1.4301	15 / 1/2"	5 barg	300 °C	5	R5
				13 barg		13	R13

**Types of connection**

- Screwed sockets ...2 \_\_\_\_ Rp thread acc. to DIN EN 10226-1 or NPT thread acc. to ANSI B1.20.1

**Features**

- Ball float steam trap with level control for the condensate-discharge from all kinds of steam systems
- Immediate discharge of condensat
- Body in welded design

**Mounting position**

- Standard: vertical / angle pattern

Types of connection		Screwed sockets
DN	(mm)	15
NPS	(inch)	1/2"

Face-to-face acc. to data sheet resp. customer request		
L	(mm)	80
L1	(mm)	80

Dimensions		
H	(mm)	138
H1	(mm)	138

Weights		
Fig. 629	(approx.) (kg)	0,9

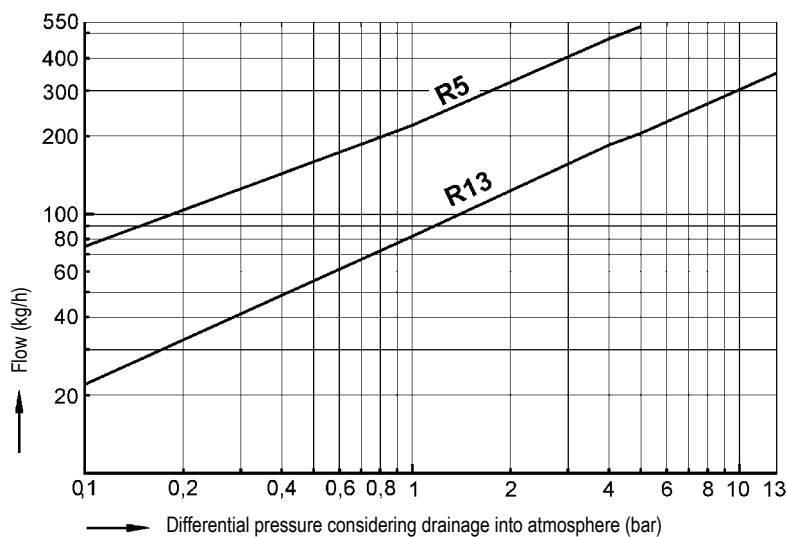
Parts		
Pos.	Description	Fig. 52.629
1	Body	X5CrNi18-10, 1.4301
24	Controller, cpl.	X5CrNi18-10, 1.4301

Information / restriction of technical rules need to be observed!

Resistance and fitness must be verified (contact manufacturer for information, refer to Product overview and Resistance list).

Operating and installation instructions can be downloaded at [www.ari-armaturen.com](http://www.ari-armaturen.com).

### Capacity chart



The capacity chart shows the maximum flow of hot boiling condensate.

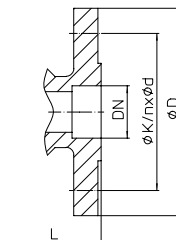
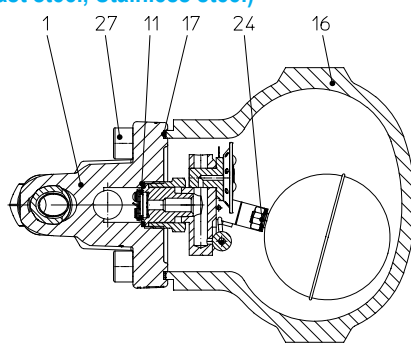
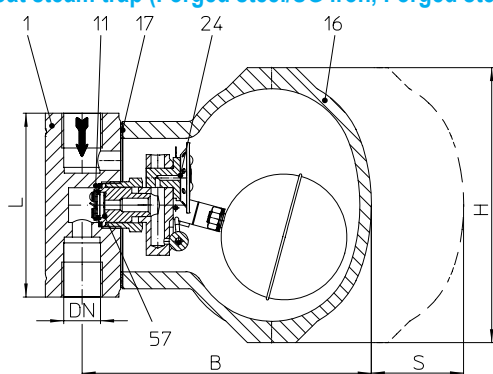
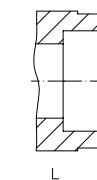
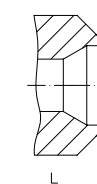
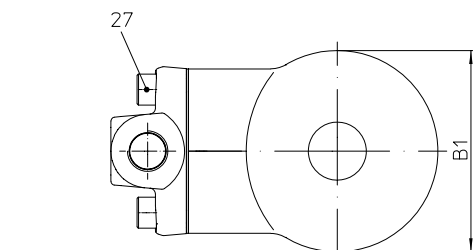
**Ball float steam trap (Forged steel/SG iron, Forged steel/Cast steel, Stainless steel)**

 Fig. 634....1  
 with flanges

 Fig. 634....3  
 with socket weld ends

 Fig. 634....4  
 with butt weld ends


Fig. 634....2 (PN16/25) with screwed sockets - vertical installation

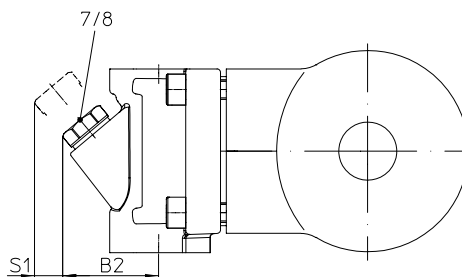


Fig. 634....2 (PN 40) with screwed sockets - horizontal installation

Figure	Nominal pressure	Material	Nominal diam. / NPS	Operating pressure PS	Inlet temperature TS	allowable differential pressure ΔPMX	for controller		
42.634	PN16	Body: 1.0460 / Hood: EN-JS1049	15 - 25 / 1/2" - 1"	4 barg	300 °C	4 bar	R4		
				14 barg			R14		
44.634	PN25	Body: 1.0460 / Hood: 1.0619+N	15 - 25 / 1/2" - 1"	4 barg	400 °C	4 bar	R4		
				14 barg					
				21 barg	225 °C			14 bar	R14
45.634 (Y)	PN40	Body: 1.0460 / Hood: 1.0619+N	15 - 25 / 1/2" - 1"	4 barg	400 °C	32 bar (PN40)	R21		
				14 barg					
				21 barg	250 °C			21 bar	R32 (PN40)
				28,3 barg					
54.634	PN25	Body: 1.4541 / Hood: 1.4308	15 - 25 / 1/2" - 1"	4 barg	300 °C	4 bar	R4		
				14 barg					
				21 barg	14 bar			R14	
55.634 (Y)	PN40	Body: 1.4541 / Hood: 1.4308	15 - 25 / 1/2" - 1"	4 barg	300 °C	32 bar (PN40)	R21		
				14 barg					
				21 barg	250 °C			21 bar	R32 (PN40)
				27,6 barg					

For ANSI versions refer to data sheet CONA®S-ANSI

Types of connection	Other types of connection on request.
<ul style="list-style-type: none"> <li>Flanges ....1 _____ acc. to DIN EN 1092-1 (PN40)</li> <li>Screwed sockets ....2 ___ Rp thread acc. to DIN EN 10226-1 or NPT thread acc. to ANSI B1.20.1</li> <li>Socket weld ends ....3 ___ acc. to DIN EN 12760</li> <li>Butt weld ends ....4 _____ Weld preparation acc. to EN ISO 9692 identification No. 1.3 and 1.5 (Note restriction on operating pressure / inlet temperature depending to design!)</li> </ul>	

Features
<ul style="list-style-type: none"> <li>Ball float steam trap with level control for the condensate-discharge from all kinds of steam systems</li> <li>Rapid system start-up due to thermostatic air venting capsule (for condensate with temperatures ≥ 100°C)</li> <li>Immediate discharge of hot boiling condensat</li> <li>Discharge of great condensate quantities even at low differential pressure</li> </ul>

- PN16 / 25 without strainer / PN40 with outside strainer - Fig. 634 (Y)
- Body with flanged hood
- Non return protection
- The controller maybe changed without disturbing the pipe work

Mounting position
<ul style="list-style-type: none"> <li>Standard: vertical</li> <li>Optional: horizontal with inlet from right or left</li> </ul>

**Please indicate when ordering!**  
 Refer to: Information about the different installation positions (Page 13)  
 On-site change of the installation position is possible according to the operating instructions.

Options
<ul style="list-style-type: none"> <li>Vent plug (Pos. 47)</li> <li>Plug (Pos. 50)</li> </ul>

- Manual air vent valve (Pos. 51)
- Ball valve for blow down (Pos. 56)

Types of connection		Flanges			Screwed sockets Socket weld ends			Butt weld ends		
DN	(mm)	15	20	25	15	20	25	15	20	25
NPS	(inch)	1/2"	3/4"	1"	1/2"	3/4"	1"	1/2"	3/4"	1"

Face-to-face acc. to data sheet resp. customer request										
L	(mm)	150	150	160	95	95	95	200 (250)	200 (250)	200 (250)

Dimensions										
										Standard-flange dimensions refer to page 13.
H	(mm)	140	140	140	140	140	140	140	140	140
B	(mm)	155	155	155	155	155	155	155	155	155
B1	(mm)	97	97	97	97	97	97	97	97	97
B2	(mm)	53	53	53	53	53	53	53	53	53
S	(mm)	120	120	120	120	120	120	120	120	120
S1	(mm)	10	10	10	10	10	10	10	10	10

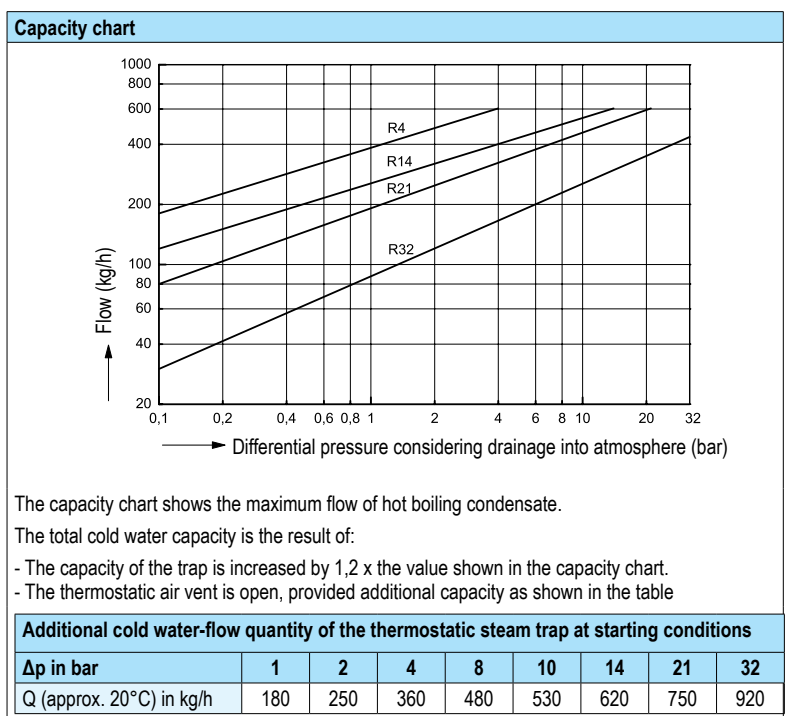
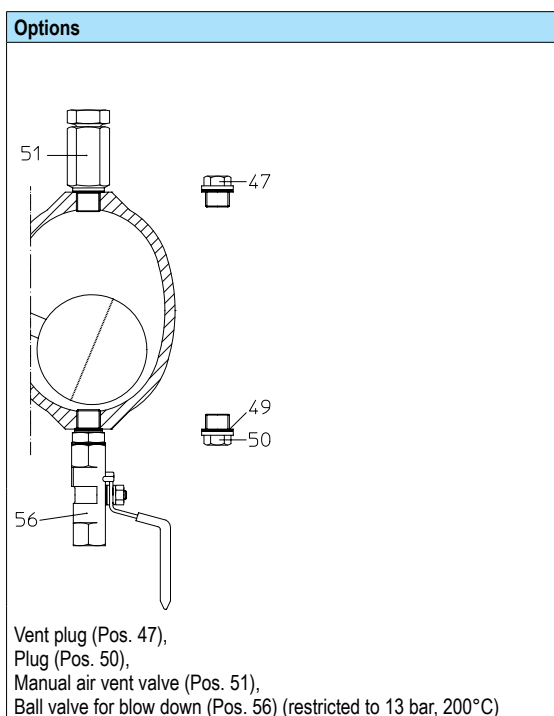
Weights										
Fig. 634 (approx.)	(kg)	6,7	6,9	7,1	4,7	4,9	5,1	5,1	5,4	5,8

Parts										
Pos.	Sp.p.	Description	Fig. 42.634	Fig. 44.634	Fig. 45.634	Fig. 54.634	Fig. 55.634			
1		Body	P250 GH, 1.0460			X6CrNiTi18-10, 1.4541				
7	x	Strainer	--		X5CrNi18-10, 1.4301	--		X5CrNi18-10, 1.4301		
8		Strainer plug	--		X6CrNiTi18-10, 1.4541	--		X6CrNiTi18-10, 1.4541		
11	x	Sealing ring	A4			A4				
16		Hood	EN-GJS-400-18U-LT, EN-JS1049	GP240GH+N, 1.0619+N		GX5CrNi19-10, 1.4308				
17	x	Gasket	GRAPHIT (CrNi laminated with graphite)							
24	x	Controller / Capsule, cpl.	X5CrNi18-10, 1.4301 / Hastelloy							
27		Cheese head screw	A2-70		21CrMoV 5-7, 1.7709		A2-70			
47		Vent plug (M14x1,5)	C35E, 1.1181			X6CrNiTi18-10, 1.4541				
49	x	Sealing ring	A4			A4				
50		Plug (M14x1,5)	C35E, 1.1181			X6CrNiTi18-10, 1.4541				
51	x	Manual air vent valve	X6CrNiTi18-10, 1.4541							
56	x	Ball valve for blow down	GX5CrNiMo19-11-2, 1.4408							
57		Non return protection	X6Cr17, 1.4016							
L Spare parts										

Information / restriction of technical rules need to be observed!

Resistance and fitness must be verified (contact manufacturer for information, refer to Product overview and Resistance list).

Operating and installation instructions can be downloaded at [www.ari-armaturen.com](http://www.ari-armaturen.com).



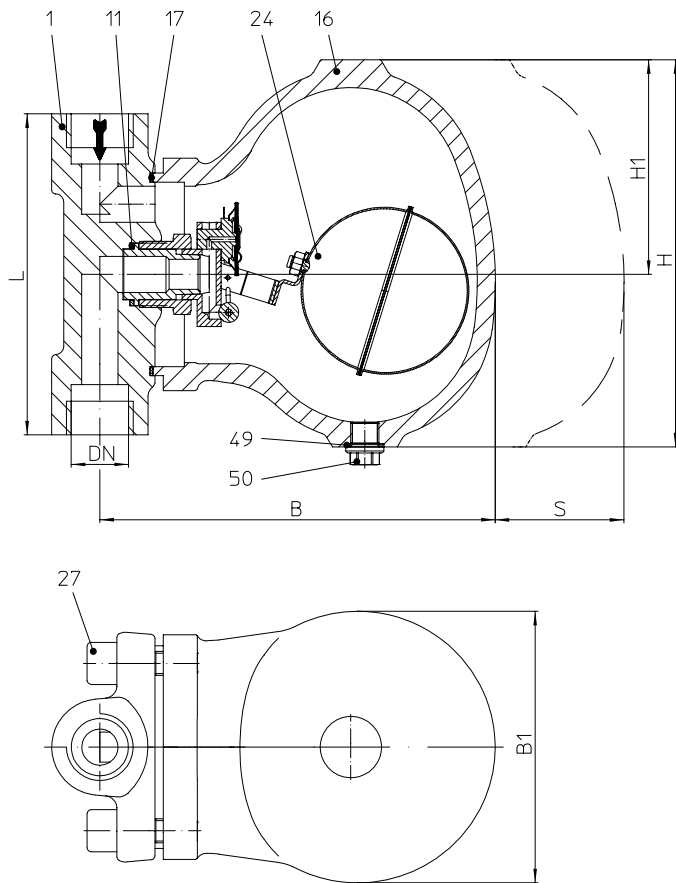
**Ball float steam trap (Grey cast iron, SG iron, Forged steel, Stainless steel)**


Fig. 635...2 with screwed sockets - vertical installation

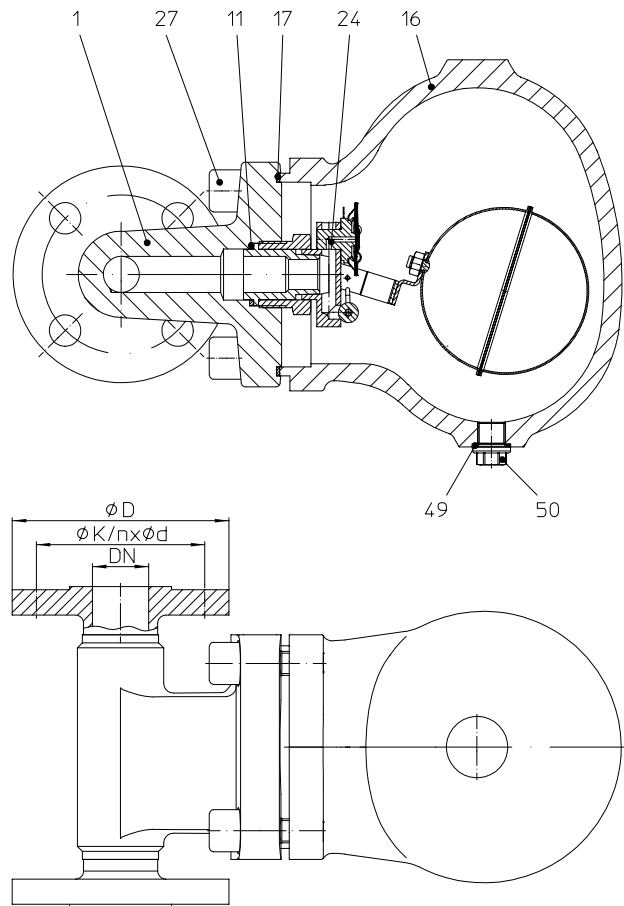


Fig. 635...1 with flanges - horizontal installation

Figure	Nominal pressure	Material	Nominal diam. / NPS	Operating pressure PS	Inlet temperature TS	allowable differential pressure ΔPMX	for controller
12.635	PN16	Body: EN-JL1040 / Hood: EN-JL1040	25 / 1"	12,8 barg 9,6 barg	200 °C 300 °C	5 bar 10 bar 14 bar	R5 R10 R14
25.635	PN40	Body: EN-JS1049 / Hood: EN-JS1049	25 / 1"	14 barg	350 °C		
45.635	PN40	Body: 1.0460 / Hood: 1.0619+N	25 / 1"	14 barg	400 °C		
55.635	PN40	Body: 1.4541 / Hood: 1.4308	25 / 1"	14 barg	300 °C		

For ANSI versions refer to data sheet CONA®S-ANSI

**Types of connection** Other types of connection on request.

- Flanges ....1 \_\_\_\_\_ acc. to DIN EN 1092-2 (EN-JL1040, EN-JS1049) and DIN EN 1092-1 (1.0460, 1.4541)
- Screwed sockets ....2 \_\_\_\_Rp thread acc. to DIN EN 10226-1 or NPT thread acc. to ANSI B1.20.1

**Features**

- Ball float steam trap with level control for the condensate-discharge from all kinds of steam systems
- Rapid system start-up due to thermostatic air venting capsule (for condensate with temperatures ≥ 100°C)
- Immediate discharge of hot boiling condensat
- Discharge of great condensate quantities even at low differential pressure
- Body with flanged hood
- The controller maybe changed without disturbing the pipe work

**Mounting position**

- |             |  |   |
|-------------|--|---|
| • Standard: | vertical                                 | <b>Please indicate when ordering!</b><br>Refer to: Information about the different installation positions (Page 13)<br>On-site change of the installation position is possible according to the operating instructions. |
| • Optional: | horizontal with inlet from right or left |   |

**Options**

- Air vent - (Pos. 51) or blow down valve (Pos. 46), manual operated

Types of connection		Flanges	Screwed sockets
DN	(mm)	25	25
NPS	(inch)	1"	1"

Face-to-face acc. to data sheet resp. customer request			
L	(mm)	160	160

Dimensions		Standard-flange dimensions refer to page 13.	
H	(mm)	193	193
H1	(mm)	107	107
B (EN-JL1040)	(mm)	250	250
B (Steel)	(mm)	250	197
B1	(mm)	136	136
S	(mm)	160	160

Weights			
Fig. 635	(approx.)	(kg)	11,8
			9,3

Parts						
Pos.	Sp.p.	Description	Fig. 12.635	Fig. 25.635	Fig. 45.635	Fig. 55.635
1		Body	EN-GJL-250, EN-JL1040	EN-GJS-400-18U-LT, EN-JS1049	P250 GH, 1.0460	X6CrNiTi18-10, 1.4541
11	x	Sealing ring	CU	A4		
16		Hood	EN-GJL-250, EN-JL1040	EN-GJS-400-18U-LT, EN-JS1049	GP240GH+N, 1.0619+N	GX5CrNi19-10, 1.4308
17	x	Gasket	GRAPHIT (CrNi laminated with graphite)			
24	x	Controller / Capsule, cpl.	X5CrNi18-10, 1.4301 / Hastelloy			
27		Cheese head screw	A2-70	21CrMoV 5-7, 1.7709		A4-80
46	x	Blow down valve	X6CrNiTi18-10, 1.4541			
49	x	Sealing ring	CU	A4		
50		Plug (M14x1,5)	C35E, 1.1181			X6CrNiTi18-10, 1.4541
51	x	Manual air vent valve	X6CrNiTi18-10, 1.4541			
		L Spare parts				

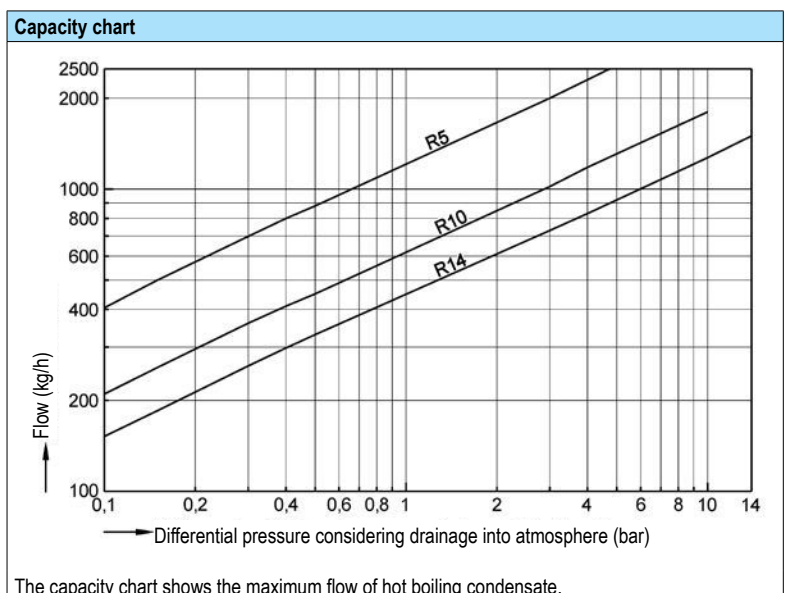
Information / restriction of technical rules need to be observed!

Resistance and fitness must be verified (contact manufacturer for information, refer to Product overview and Resistance list).

Operating and installation instructions can be downloaded at [www.ari-armaturen.com](http://www.ari-armaturen.com).

**Options**

Air vent - (Pos. 51) or blow down valve (Pos. 46), manual operated



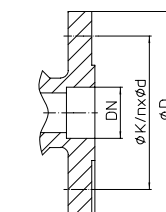
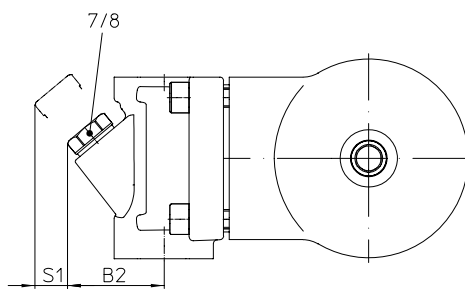
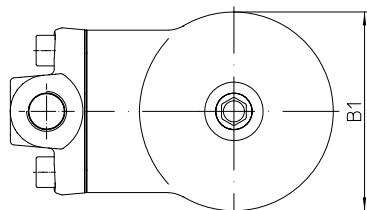
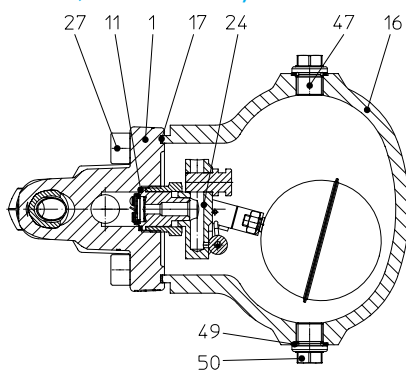
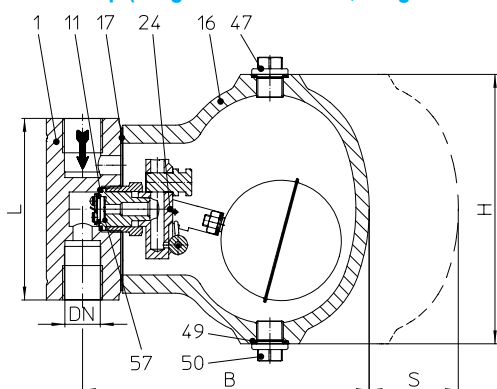
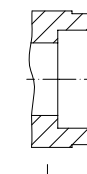
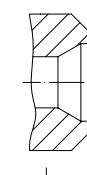
**Ball float steam trap (Forged steel/SG iron, Forged steel/Cast steel, Stainless steel)**

 Fig. 636....1  
with flanges

 Fig. 636....3  
with socket weld ends

 Fig. 636....4  
with butt weld ends

Fig. 636....2 (PN16/25) with screwed sockets - vertical installation

Fig. 636....1 (PN 40) with screwed sockets - horizontal installation

Figure	Nominal pressure	Material	Nominal diam. / NPS	Operating press. PS	Inlet temperature TS	allowable differential pressure ΔPMX	for controller	
42.636	PN16	Body: 1.0460 / Hood: EN-JS1049	15 - 25 / 1/2" - 1"	4 barg	300 °C	4 bar	R4	
				14 barg			R14	
44.636	PN25	Body: 1.0460 / Hood: 1.0619+N	15 - 25 / 1/2" - 1"	4 barg	400 °C	4 bar	R4	
				14 barg				
				21 barg	225 °C			
45.636 (Y)	PN40	Body: 1.0460 / Hood: 1.0619+N	15 - 25 / 1/2" - 1"	4 barg	400 °C	32 bar (PN40)	R14	
				14 barg				
				21 barg	250 °C			R21
				28,3 barg				R32 (PN40)
54.636	PN25	Body: 1.4541 / Hood: 1.4308	15 - 25 / 1/2" - 1"	4 barg	300 °C	4 bar	R4	
				14 barg				
				21 barg				
55.636 (Y)	PN40	Body: 1.4541 / Hood: 1.4308	15 - 25 / 1/2" - 1"	4 barg	300 °C	32 bar (PN40)	R14	
				14 barg				
				21 barg	250 °C			R21
				27,6 barg				R32 (PN40)

For ANSI versions refer to data sheet CONA®S-ANSI

**Types of connection** Other types of connection on request.

- Flanges ....1 \_\_\_\_\_ acc. to DIN EN 1092-1 (PN40)
- Screwed sockets ....2 \_\_\_\_\_ Rp thread acc. to DIN EN 10226-1 or NPT thread acc. to ANSI B1.20.1
- Socket weld ends ....3 \_\_\_\_\_ acc. to DIN EN 12760
- Butt weld ends ....4 \_\_\_\_\_ Weld preparation acc. to EN ISO 9692 identification No. 1.3 and 1.5 (Note restriction on operating pressure / inlet temperature depending to design!)

**Features**

- Ball float steam trap with level controller for the condensate-discharge from compressed air and gas systems (acc. to PED 2014/68/EU fluid group 2, other fluid groups on request)
- Discharge of great condensate quantities even at low differential pressure
- PN16 / 25 without strainer / PN40 with outside strainer (Y)
- Body with flanged hood
- Non return protection
- The controller maybe changed without disturbing the pipe work

**Mounting position**

- |             |   |   |
|-------------|---|---|
| • Standard: | - vertical  | <b>Please indicate when ordering!</b><br>Refer to: Information about the different installation positions (Page 13)<br>On-site change of the installation position is possible according to the operating instructions. |
| • Optional: | - horizontal with inlet from right or left<br>- horizontal with adapter for recovery pipe (union joint).<br>Example for installation ref. to page 10. |   |

**Options**

- Manual air vent valve (Pos. 51)
- Ball valve for blow down (Pos. 56)
- Union (Pos. 52) for recovery pipe (for connecting pipes with outside-Ø 8 x 1 mm acc. to EN 10305-4 steel or EN 10216-5 stainless steel, compression type fitting acc. to DIN 2353)
- Soft sealing ball FKM (Viton), max. 120°C



Types of connection		Flanges			Screwed sockets Socket weld ends			Butt weld ends		
DN	(mm)	15	20	25	15	20	25	15	20	25
NPS	(inch)	1/2"	3/4"	1"	1/2"	3/4"	1"	1/2"	3/4"	1"

Face-to-face acc. to data sheet resp. customer request										
L	(mm)	150	150	160	95	95	95	200 (250)	200 (250)	200 (250)

Dimensions										
Standard-flange dimensions refer to page 13.										
H	(mm)	156	156	156	156	156	156	156	156	156
B	(mm)	155	155	155	155	155	155	155	155	155
B1	(mm)	97	97	97	97	97	97	97	97	97
B2	(mm)	53	53	53	53	53	53	53	53	53
S	(mm)	120	120	120	120	120	120	120	120	120
S1	(mm)	10	10	10	10	10	10	10	10	10

Weights										
Fig. 636 (approx.)	(kg)	6,7	6,9	7,1	4,7	4,9	5,1	5,1	5,4	5,8

Parts										
Pos.	Sp.p.	Description	Fig. 42.636	Fig. 44.636	Fig. 45.636	Fig. 54.636	Fig. 55.636			
1		Body	P250 GH, 1.0460			X6CrNiTi18-10, 1.4541				
7	x	Strainer	--		X5CrNi18-10, 1.4301	--	X5CrNi18-10, 1.4301			
8		Strainer plug	--		X6CrNiTi18-10, 1.4541	--	X6CrNiTi18-10, 1.4541			
11	x	Sealing ring	A4			A4				
16		Hood	EN-GJS-400-18U-LT, EN-JS1049	GP240GH+N, 1.0619+N		GX5CrNi19-10, 1.4308				
17	x	Gasket	GRAPHIT (CrNi laminated with graphite)							
24	x	Controller, cpl.	X5CrNi18-10, 1.4301							
27		Cheese head screw	A2-70		21CrMoV 5-7, 1.7709	A2-70				
47		Vent plug (M14x1,5)	C35E, 1.1181			X6CrNiTi18-10, 1.4541				
49	x	Sealing ring	A4			A4				
50		Plug (M14x1,5)	C35E, 1.1181			X6CrNiTi18-10, 1.4541				
51	x	Manual air vent valve	X6CrNiTi18-10, 1.4541							
52	x	Union for recovery pipe	X8CrNiS18-9, 1.4305							
56	x	Ball valve for blow down	GX5CrNiMo19-11-2, 1.4408							
57		Non return protection	X6Cr17, 1.4016							
L Spare parts										

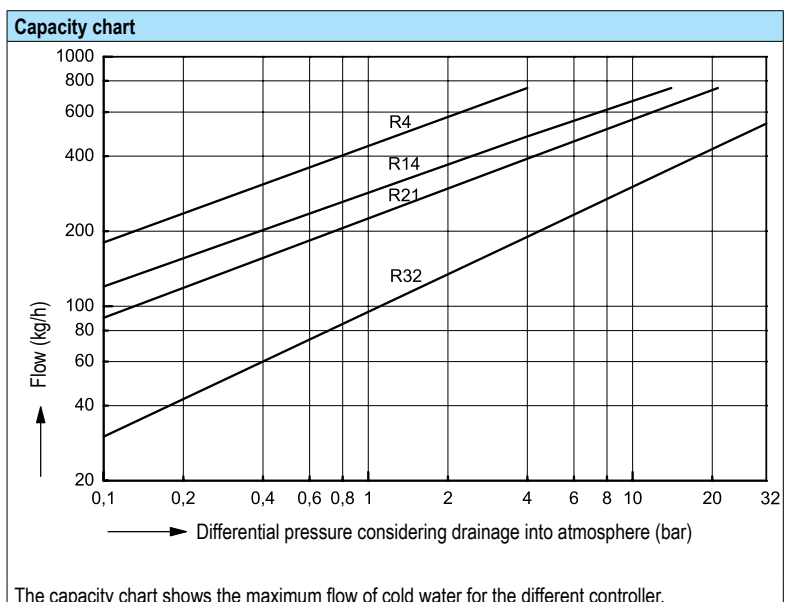
Information / restriction of technical rules need to be observed!

Resistance and fitness must be verified (contact manufacturer for information, refer to Product overview and Resistance list).

Operating and installation instructions can be downloaded at [www.ari-armaturen.com](http://www.ari-armaturen.com).

**Options**

Manual air vent valve (Pos. 51),  
 Union (Pos. 52) for pressure compensation line,  
 Ball valve for blow down (Pos. 56) (restricted to 13 bar, 200°C)

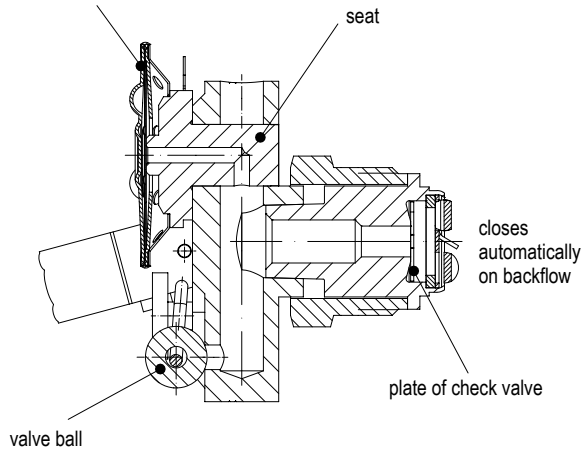


Informations about pipe welding		
<b>Welding groove acc. to DIN 2559</b>		
The material used for ARI valves with butt weld ends are:	1.0460	P250GH acc. to DIN EN 10222-2
<b>Note:</b>	1.4541	X6CrNiTi18-10 acc. to DIN EN 10222-5
Note restriction on operating pressure / inlet temperature depending to design!		
<p>Due to our experience, we recommend to apply an electric welding process.</p> <p>Because of the different material compositions and wall thickness of the steam traps and the pipe gas welding shall not be applied. Quenching cracks and coarse grain structure may develop.</p> <p>Steam traps with socket-weld ends shall only be welded by arc welding (welding process 111 acc. to DIN EN 24063).</p> <p>If during the time of warranty others than the manufacturer or by the manufacturer authorized persons are interfering in the product and/or the setting, the right of claim for warranty will lapse!</p>		

Selection criteria:	Example for order data:
<ul style="list-style-type: none"> <li>• Steam pressure</li> <li>• Back pressure</li> <li>• Quantity of condensate</li> <li>• Flow medium</li> <li>• Nominal diameter / pressure</li> <li>• Type of connection</li> <li>• Material</li> <li>• Place of service or kind of steam consumer</li> </ul>	<p><b>Ball float steam trap CONA® SC, Fig. 634, PN25, DN25, 1.0460/1.0619+N, R14, with flanges, Face-to-face dimension 160 mm</b></p>
<p><b>Other installation positions than standard (vertical) have to be indicated together with the information about the flow direction i.e. inlet from left or right</b></p>	

Integrated non return protection

automatic ventilation (for Fig. 634/635)

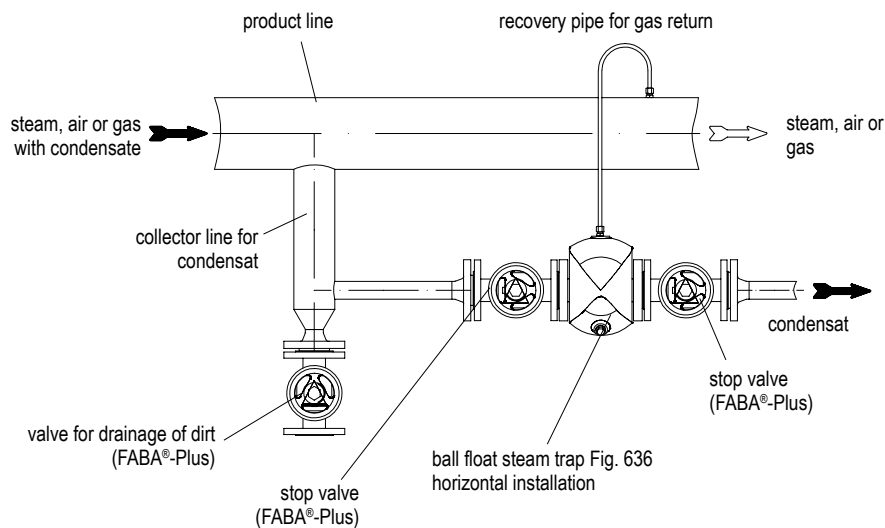


The internal plate acts at series 634 and 636 as integrated check valve.

In case of parallel installed heat exchangers or heater batteries the non return protection prevents a shut down heat-exchanger for flooding with condensate from the downstream side and reverse heating up.

A check valve which otherwise has to be installed is not necessary.

Installation with recovery pipe



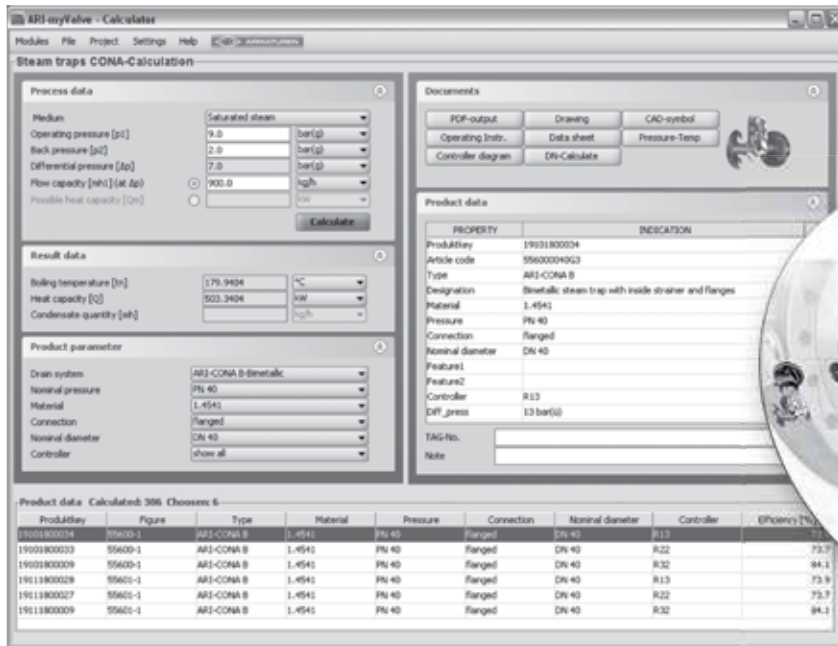
**Important:**

The installation of a recovery pipe for gas return is always recommended; especially if the ball float steam trap is installed horizontally.

W. T. Maye, Inc.  
1-877-705-9864  
info@wtmi-usa.com  
www.wtmi-usa.com

**myValve® - Your Valve Sizing-Program.**

myValve is a powerful software tool that not only helps you size your system components; it also gives you instant access to all other data about the selected product, such as order information, spare parts drawings, operating instructions, data sheets, etc., whenever you need it.


**myValve - Valve Sizing-Program**
**Contents:**
**Module ARI-Steam trap CONA-Calculation**

- Sizing (calculation of steam trap systems with given flow capacity or heat capacity)
- Calculation of nominal diameter acc. to given pressure, condensate quantity, condensate sub-cooling and speed

**Media:**

- Steam (saturated and superheated)
- Compressed air

**Special Features**

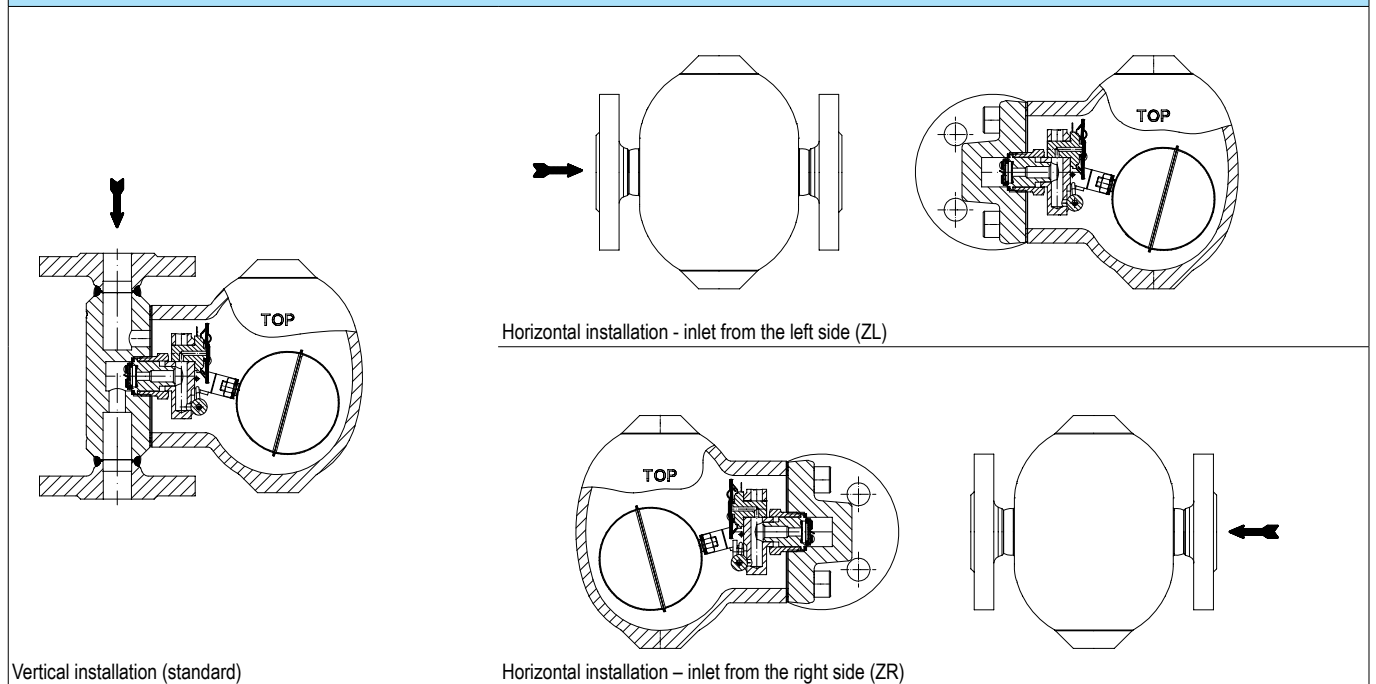
- Project administration of the calculation and product data incl. spare part drawings concerning to project and tag number
- Direct output or calculation and product data in PDF format
- Product data could be taken for a direct order
- SI- and ANSI-units with direct conversion to another databank
- Settings with over pressure or absolute pressure
- All ARI products are integrated in one databank
- Direct access concerning to the product on data sheets, operating instructions, pressure-temperature-diagram and spare part drawings
- Operation in company networks possible (no complex installations on individually PC's necessary)
- Extensive catalogue extending over several product groups

**System Requirements:**

Windows operating systems, Linux, etc.

W. T. Maye, Inc.  
 1-877-705-9864  
 info@wtmi-usa.com  
 www.wtmi-usa.com

Standard-flange dimensions acc. to 1092-1 / -2					
<b>DN</b>		(mm)	<b>15</b>	<b>20</b>	<b>25</b>
<b>NPS</b>		(inch)	<b>1/2"</b>	<b>3/4"</b>	<b>1"</b>
<b>PN16</b>	ØD	(mm)	95	105	115
	ØK	(mm)	65	75	85
	n x Ød	(mm)	4 x 14	4 x 14	4 x 14
<b>PN25</b>	ØD	(mm)	95	105	115
	ØK	(mm)	65	75	85
	n x Ød	(mm)	4 x 14	4 x 14	4 x 14
<b>PN40</b>	ØD	(mm)	95	105	115
	ØK	(mm)	65	75	85
	n x Ød	(mm)	4 x 14	4 x 14	4 x 14

**Information about the different installation positions (shown at Fig. 634 CONA SC)**

**Installation (see picture)**

The ball float steam traps can be installed either in vertical (standard) or horizontal position. In case of horizontal installation please indicate whether the inlet is from the left or right side.

The steam trap can also be converted on site to match the different installation positions. Please observe the appropriate operating manuals.

The steam trap must be fitted with the direction of flow as indicated by the arrow on the body.

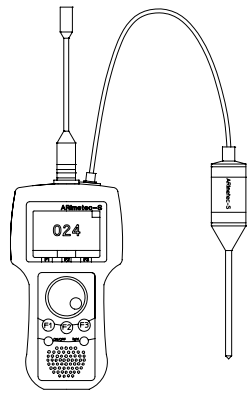
Enough clearance (refer to dimension S) for the removal of the hood shall be provided.

The steam trap shall preferably be installed at the lowest point of the system and the membrane capsule resp. the bleeding tube shall be installed in an upright position inside of the hood.

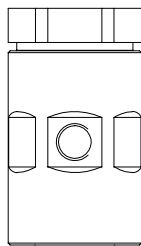
**For the modification of the installation position observe the operating manual.**

A modification of the installation position during the time of warranty shall be carried out by the AWH-Service or it shall be agreed between the customer and manufacturer.

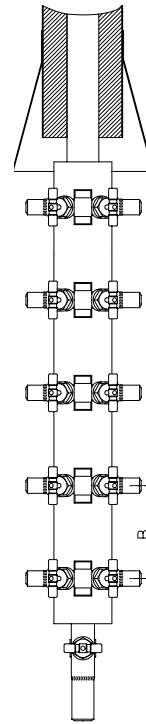
W. T. Maye, Inc.  
 1-877-705-9864  
 info@wtmi-usa.com  
 www.wtmi-usa.com



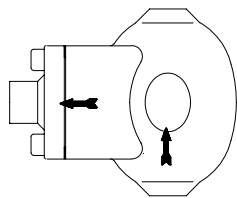
Multifunction tester ARImetec®-S



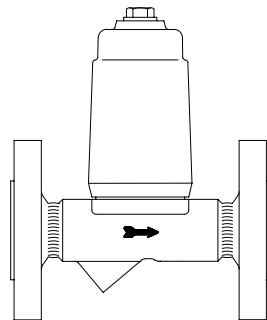
Vacuum breaker  
Fig. 655



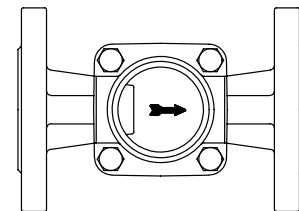
Condensate collection (B = 160), steam distribution (B = 120)  
CODI®S with gland packing Fig. 671/672;  
CODI®B with bellows seal, maintenance-free Fig. 675/676



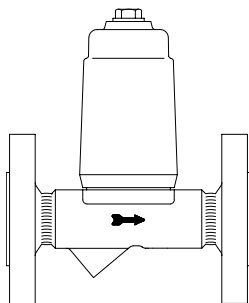
Automatic air vent for liquid systems  
Fig. 656



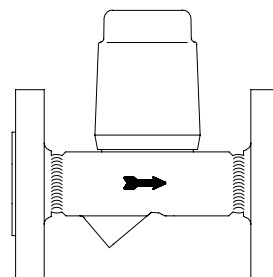
Condensate discharge temperature limiter  
Fig. 645/647



Flow indicator  
Fig. 660/661



Return temperature limiter  
Fig. 650



Liquid drainer  
Fig. 665

(Further informations about the accessories can be found in the appropriate data sheets.)

W. T. Maye, Inc.  
1-877-705-9864  
info@wtmi-usa.com  
www.wtmi-usa.com



ISO 9001



WHG §19 I

